

Border Lite Twin

Cat. No. BLT
Cat. No. BLT/R



HUNZA®

The Border Lite Twin has two individual heads which can be aimed in different directions, making it ideal for path lighting giving a wide spread of light with no upward projection. Each light has a fully adjustable arm allowing 360 degree rotation and 0 - 90 degree elevation.

The Retro™, which is a mains option, avoids the need to bury a transformer. The 110/240-12 volt electronic transformer is built into the pole and is a double insulated safety isolating transformer, this changes the luminaire to an IP56 rating.

This luminaire is equipped with Hunza's Anti-Syphon™ (not Retro luminaires) system which has been designed to counter the problem of wicking (siphoning) of water through the supply cable into the lamp housing, causing water to condense and dramatically shorten the life of the lamp, lamp holder and luminaire.

Ordering Information

Luminaire Type

BLT - Border Lite Twin

Material/Finish

BK - Black
GN - Green
STAR - Silver Star
WH - White
SS - 316 Stainless Steel
BRZ - Solid Bronze

Accessories

CJK150 - CJK150 Cable Joint Kit
BCL - Clear Lens
/R - Retro™ Transformer
110/240-12 volt
SSP/G - Hunza® Super Spike

Ordering Example: BLT BRZ - Border Lite Twin in Solid Bronze

BLT/R BK - Border Lite Twin Retro™ Black

SSP/G - Hunza® Super Spike

(Accessories ordered separately)

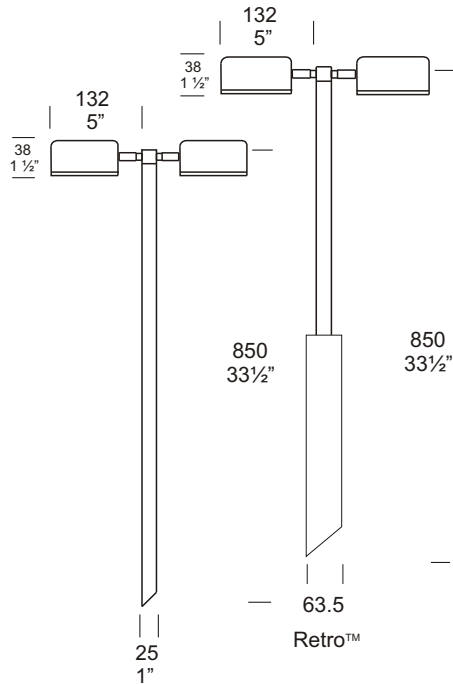

FACTORY: Ph: 64-9-528 9471 Fax: 64-9-528 9361.

USA: Ph. 310 560 7310 Fax. 1 877 692 4589.

hunza@hunza.co.nz www.hunza.co.nz

Specifications may change without notice.

130 Felton Mathew Ave, Glen Innes, Auckland, New Zealand.

3237 Long Island St, W. Sacramento, California 95691, USA.

Manufactured in New Zealand.

Ver 1.4

© 2009 Hunza Holdings Ltd

Luminaire Construction

Aluminium

Head:

Cast from virgin high corrosion resistant CC401 low copper aluminium alloy, with chromate substrate and high UV resistant polyester powder coat

Colours: Black, Green, Silver Star, White.

Poles: Aluminium, 25.4mm (1") x 850mm (33½") tube.

Retro™: Pole - 25.4mm (1") x 410mm (16") tube.

Transformer Pole 63.5mm (2½") x 440mm (17½").

Solid Bronze

Head: Cast from LG2 Bronze

Poles: Copper, 25.4mm (1") x 850mm (33½") tube.

Stainless Steel

Head: Investment cast 316 Stainless Steel.

Poles: 316 Stainless Steel, 25.4mm (1") x 850mm (33½") tube.

Mounting

Pole 850mm (33½") directly mounted into the earth or for extra stability in sand or loose ground use a Hunza® Super Spike.

Features

Cable:

Water resistant rubber and PVC with HUNZA® Anti-Syphon™ water barrier system.

Lens:

47mm (1¹³/₁₆") x 47mm (1¹³/₁₆") x 3mm (1/8") Frosted tempered shatter resistant glass.
Life Time Warranty.

Gaskets:

Nyrol rubber, 150°C (302°F).

Lamp Holder:

G4 - 350°C (662°F) ceramic multi contact lamp holder with 250°C (480°F) teflon cables.

Accessories:

Cable Joint Kit (Cat. CJK 150).

Hunza® Super Spike, not Retro™ option (Cat. SSP/G).

Clear Lens (Cat. BCL).

Retro™ transformer 110/240-12 volt (Cat. /R).

Swivel:

360° rotation and 0 - 90° elevation, solid brass with anti rust spring.

Standards

IP56 / IP66  UL1838

Luminaire Weight

12 volt:

Alum: .900kg (1lb 15oz)

BRZ: 2.100kg (4lb 10oz)

SS: 1.800kg (3lb 15oz)

Retro™:

Alum: 2.245kg (4lb 15oz)

BRZ: 3.800kg (8lb 6oz)

SS: 3.500kg (7lb 11oz)

Power Supply

HUNZA® Inground or Wall Mount Transformer: not included.

RETRO™ IP56

HUNZA® 110/240-12 volt ac silicone encapsulated electronic transformer is built into the pole. Dimmable with a suitable leading edge dimmer. * Note see page 7.3 for details.

USA and Canada:

HUNZA® Wall Mount Transformer: not included.

Luminaire: supplied with

2 x G4 Bi - Pin 20 watt lamp max.

Retro™ 2 x G4 Bi - Pin 20 watt lamp max.

USA and Canada:

2 x G4 Bi - Pin 20 watt lamp max.

Retro™ 2 x G4 Bi - Pin 20 watt Lamp max.

Twin Border Lite G4 20 watt lamp lens height 600mm (24")

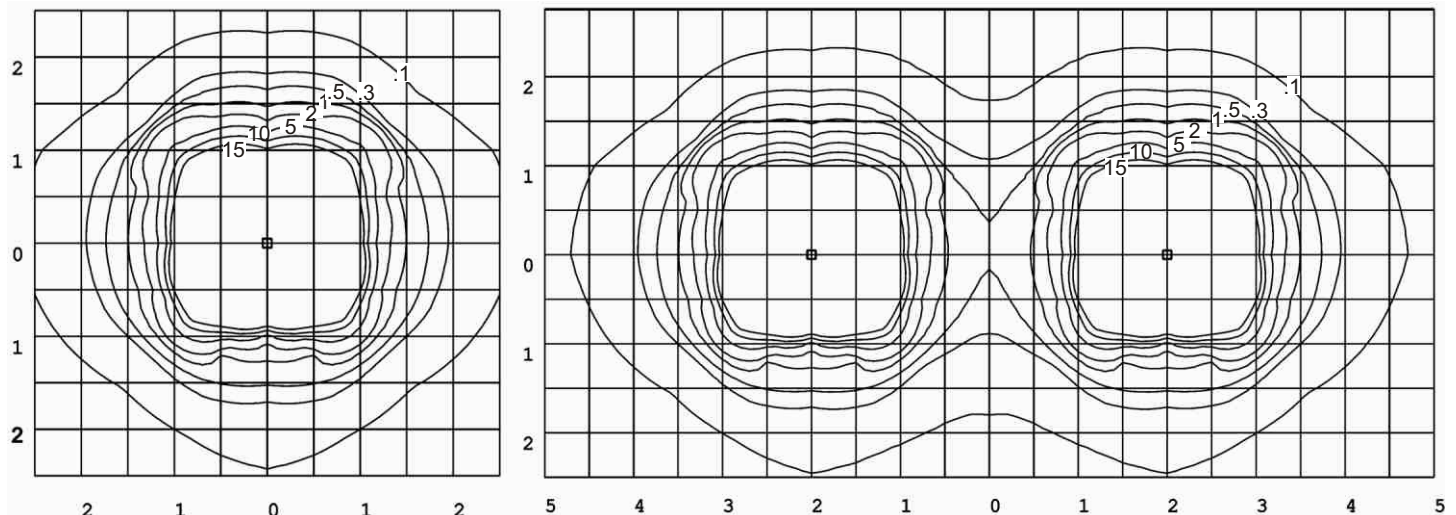

FACTORY: Ph: 64-9-528 9471 Fax: 64-9-528 9361.

USA: Ph. 310 560 7310 Fax. 1 877 692 4589.

hunza@hunza.co.nz www.hunza.co.nz

Specifications may change without notice.

130 Felton Mathew Ave, Glen Innes, Auckland, New Zealand.

3237 Long Island St, W. Sacramento, California 95691, USA.

Manufactured in New Zealand.

Ver 1.4

© 2009 Hunza Holdings Ltd