

Cockpit Lite

Cat. No. CPL

[Click here for specifications on this luminaire](#)

[Return to main index](#)



The Cockpit Lite, designed for marine applications, is used with a 5 watt bi-pin lamp or LED Array and has a frosted glass lens to create a glow in the cockpit at night. The PVC mounting canister is fully enclosed with a cable gland which clamps the cable to maintain IP66 rating. If the cockpit fills with water the canister will not compromise the cockpits waterproof integrity.

Ordering Information

Luminaire Type

CPL - Cockpit Lite

Material

SS - 316 Stainless Steel

Accessories

CJK150 - Cable Joint Kit
ECL - Clear Lens
LED - LED Array

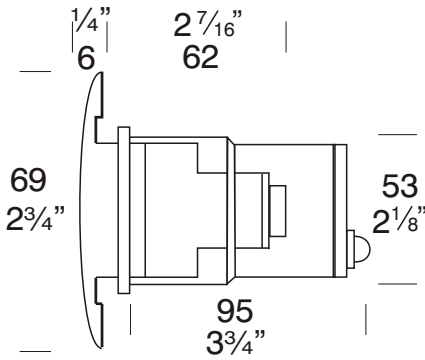

Ordering Example: CPL - Cockpit Lite in 316 Stainless Steel.

CJK150 - Cable Joint Kit
(Accessories ordered separately)



FACTORY: Ph: 64-9-528 9471 Fax: 64-9-528 9361.

USA: Ph. 310 560 7310 Fax. 1 877 692 4589.

hunza@hunza.co.nz www.hunza.co.nz

Specifications may change without notice.

130 Felton Mathew Ave, Glen Innes, Auckland, New Zealand.

3237 Long Island St, W. Sacramento, California 95691, USA.

Manufactured in New Zealand.

© 2004 Hunza Holdings Ltd

Ver 1.2

Luminaire Construction

CNC machined from:

Body:

316 Stainless steel: 45mm (1¾") rod.

Flange:

70mm (3½") solid 316 stainless steel rod.

Canister:

Engineering grade PVC with nylon cable gland.

Mounting

The Cockpit Lite is fixed in place using the locking ring on the canister. It will mount into material up to 12mm thick. There are no mounting screws in the flange to spoil the luminaire aesthetics.

Features

Lens:

3mm (1/8") thick frost tempered shatter resistant glass.

Life Time Warranty.

Gaskets:

Silicone, iron impregnated 220°C (428°F).

Lamp Holder:

GU4 - 350°C (662°F) ceramic multi contact lamp holder with 250°C (480°F) teflon cables.

Accessories:

Cable Joint Kit (Cat. CJK 50)
Not approved for USA /Canada.

Clear Lens (Cat. ECL).

LED Array Red, Blue, White, Yellow, Green (Cat. LED). Refer sheet 8.4

Standards

IP66

Luminaire Weight

SS .420kg (15oz)

Power Supply

HUNZA® IG20

LED Refer sheet no. 8.4

Luminaire: supplied with

Halogen

GU4 Bi-Pin lamp 5 watt max.

LED

LED - Refer sheet no. 8.4



FACTORY: Ph: 64-9-528 9471 Fax: 64-9-528 9361.

USA: Ph. 310 560 7310 Fax. 1 877 692 4589.

hunza@hunza.co.nz www.hunza.co.nz

Specifications may change without notice.

130 Felton Mathew Ave, Glen Innes, Auckland, New Zealand.

3237 Long Island St, W. Sacramento, California 95691, USA.

Manufactured in New Zealand.

Ver 1.2

© 2004 Hunza Holdings Ltd