

# E-Lite

Cat. No. Ecop

Cat. No. Ess



The E-Lite is ideal for lighting eaves, soffits, entrance ways, verandahs or carports and covered decks. Bathrooms, kitchens or where a moisture transfer rating or a decibel rating is a minimum requirement.

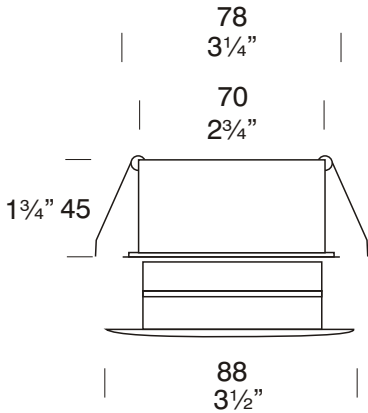

### Ordering Information

#### Luminaire Type

E - E-Lite

#### Colour

- BK - Black
- WH - White
- COP - Copper
- SS - 316 Stainless

#### Accessories

- CJK150 - Cable Joint Kit
- EFL - Frost Lens
- LED - LED Array



Ordering Example: ECOP / LED- E- Lite with LED Array in copper.

Patent Pending



**FACTORY:** Ph: 64-9-528 9471 Fax: 64-9-528 9361.

**USA:** Ph. 310 560 7310 Fax. 1 877 692 4589.

hunza@hunza.co.nz www.hunza.co.nz

Specifications may change without notice.

130 Felton Mathew Ave, Glen Innes, Auckland, New Zealand.

3237 Long Island St, W. Sacramento, California 95691, USA.

Manufactured in New Zealand.

© 2005 Hunza Holdings Ltd

Ver 1.3

## E-Lite Construction

CNC machined from :

**Aluminium** body high corrosion resistant 90mm (3½") solid aluminium rod with chromate substrate and high UV resistant polyester powder coat.

Colours Black or White.

**Copper** body solid copper rod 90mm (3 ½")

**316 Stainless** body 316 stainless steel 90mm (3 ½")

### Canister

316 stainless steel

### Mounting

Via canister supplied, which maintains the aesthetic look of the flange by eliminating any mounting holes in the flange. The canister is designed to fit through a 70mm (2 5/8") hole and be fixed into position by two spring clips. The luminaire is held in the canister by an O ring.

## Features

### Lens:

3mm (1/8") clear tempered shatter resistant glass. A clear lens is fitted as standard.

### Lamp Holders:

GU5.3 - 350°C (662°F) ceramic multi contact lamp holder with 250°C (480°F) teflon cables.

### Accessories:

Cable Joint Kit (CJK150)

Frost Lens (Cat.EFL)

LED Array (LED)

## Standards

### IPX5

NZCEP 54 = CA, SCB 100mm  
HBX 75mm, REC 135mm  
DB = RW30

### Weight

100gms (4 oz)

### Power Supply

HUNZA® H20, H40 or H50  
Transformer: not included.

**LED** - Refer sheet no. 8.4

Suitable for use with Halogen  
MR16 GU5.3 50 watt lamp max.

**LED** - Refer sheet no. 8.4

Lamp/LED not supplied

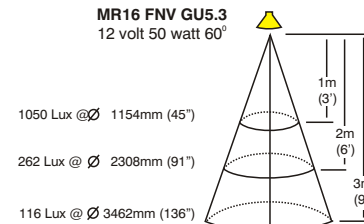
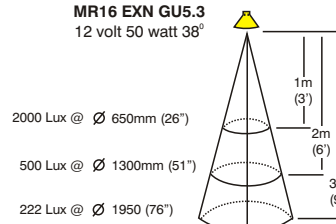
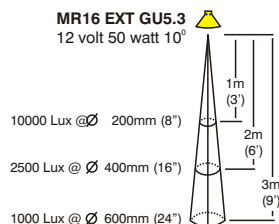
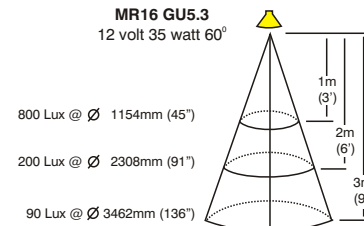
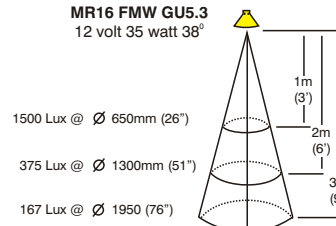
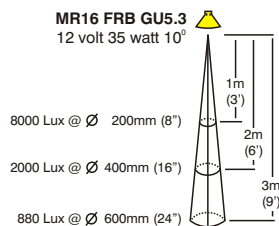
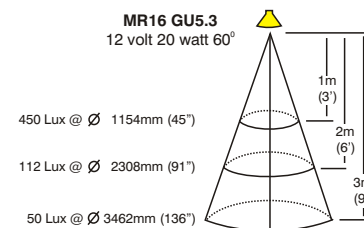
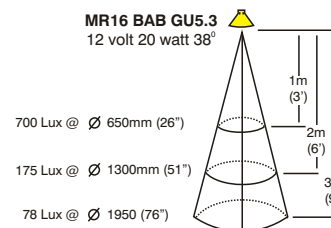
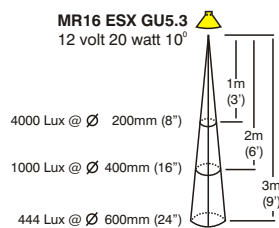

**FACTORY:** Ph: 64-9-528 9471 Fax: 64-9-528 9361.

**USA:** Ph. 310 560 7310 Fax. 1 877 692 4589.

hunza@hunza.co.nz www.hunza.co.nz

Specifications may change without notice.

130 Felton Mathew Ave, Glen Innes, Auckland, New Zealand.

3237 Long Island St, W. Sacramento, California 95691, USA.

Manufactured in New Zealand.

© 2005 Hunza Holdings Ltd

Ver 1.3