

# E-Lite Metal Halide

Cat. No. EAVEMH20

Cat. No. EAVEMH35



The E-Lite is a recessed downlighter ideal for installation in eaves, soffits, entrance ways, verandahs, carports or covered decks. It can also be used in bathrooms, kitchens or where moisture transfer or decibel rating is a minimum requirement.

The 316 stainless steel E-Lite is electro-polished to increase corrosion protection.

Metal Halide lamps are highly energy efficient light sources using less energy and out putting 2 - 3 times the light of a halogen lamp. This luminaire has a MR16 GX10 20 or 35 watt lamp.

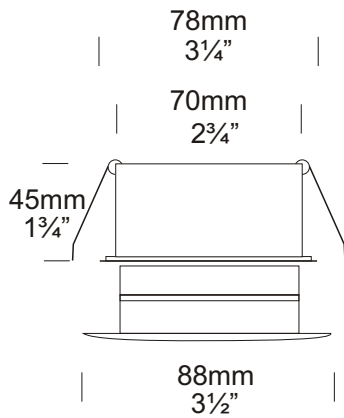

## Ordering Information

Luminaire Type	Material	Accessories
EAVEMH20 - E-Lite Metal Halide 20 watt	BK - Black WH - White	CJK150 - Cable Joint Kit LENSSTEPF - Frost Lens
EAVEMH35 - E-Lite Metal Halide 35 watt	COP - Copper SS - 316 Stainless	

Ordering Example: EAVEMH20 SS - E Lite Metal Halide 20 watt in 316 Stainless Steel



**HUNZA**™ PURE OUTDOOR LIGHTING

**HUNZA FACTORY**  
130 Felton Mathew Ave  
Glen Innes  
Auckland 1072  
New Zealand

Ph: 64-9-528 9471  
Fax: 64-9-528 9361  
hunza@hunza.co.nz  
www.hunza.co.nz

**INTERNATIONAL CONTACTS:**  
[www.hunza.co.nz/contacts.php](http://www.hunza.co.nz/contacts.php)

Specifications may change without notice.  
Manufactured in New Zealand.

© 2009 Hunza Holdings Ltd.

Ver 1.4

## Luminaire Construction

CNC machined from:

**Aluminium** body high corrosion resistant 90mm (3½") solid aluminium rod with chromate substrate and high UV resistant polyester powder coat.

**Colours** Black or White.

**Copper** body 90mm (3½").

**316 Stainless Steel** body 88mm (3½") Electro-polished.

**Canister** 316 stainless steel

### Mounting

Via canister supplied, which maintains the aesthetic look of the flange by eliminating any mounting holes in the flange. The canister is designed to fit through a 70mm (2 5/8") hole and be fixed into position by two spring clips. The luminaire is held in the canister by an O ring.

*The stainless steel E-Lite is electro-polished, this finish increases the protection against corrosion by up to 33%.*

## Features

**Lens:**

10mm (3/8") clear flush fit shatter resistant glass.

Life Time Warranty

**Gasket:**

Silicone, iron impregnated 220°C (428°F)

**Lamp Holder:**

GX10 - 350°C (662°F) ceramic multi contact lamp holder with 250°C (480°F) teflon cables.

**Accessories:**

Cable Joint Kit (Cat. CJK150).

Frosted Lens (Cat. LENSSTEPF).

## Standards

AS/NZS 60598.2.2 IP66

### Luminaire Weight

Alum .300 kg (11oz)

Cop .800 kg (1lb 12oz)

SS .750 kg (1lb 10oz)

### Power Supply

Supplied with a Remote Ballast:  
230 - 240 volt ac 50 Hz.

**USA and Canada:**

Remote Ballast: 120 volt ac 60Hz.

**Luminaire: supplied with**  
MR16 GX10 20 or 35 watt lamp.

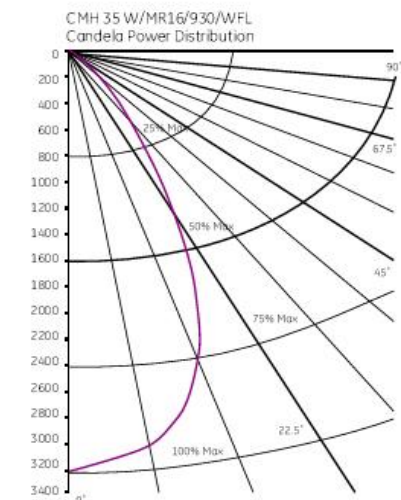
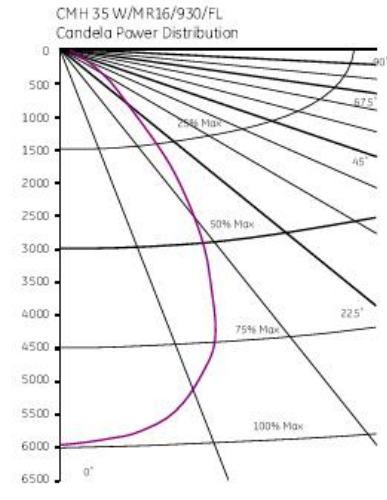
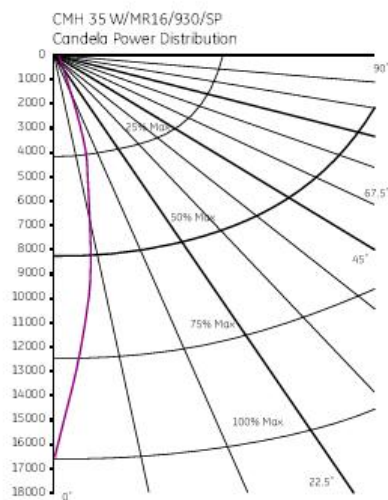
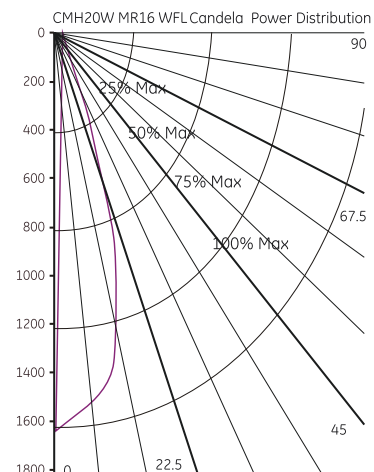
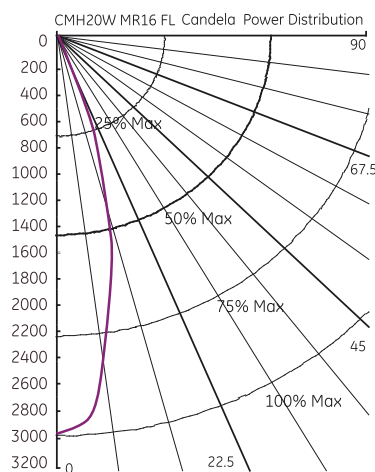
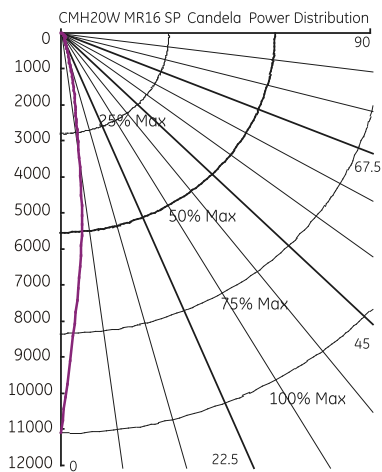

**HUNZA**™ PURE OUTDOOR LIGHTING

**HUNZA FACTORY**  
130 Felton Mathew Ave  
Glen Innes  
Auckland 1072  
New Zealand

Ph: 64-9-528 9471  
Fax: 64-9-528 9361  
hunza@hunza.co.nz  
www.hunza.co.nz

**INTERNATIONAL CONTACTS:**  
www.hunza.co.nz/contacts.php

Specifications may change without notice.  
Manufactured in New Zealand.

© 2009 Hunza Holdings Ltd.

Ver 1.4