

Euro Step Lite

Cat. No. ESL



The Euro Step is designed for use with an MR11 lamp. It has a 69mm flange for flush mounting into masonry, stone or wood. For illumination of steps and ground level horizontal lighting, for example, across driveways or exterior paved areas. There are no mounting screws in the flange to spoil the aesthetics of this luminaire.

Ordering Information

Luminaire Type	Material	Accessories
ESL - Euro Step Lite	COP - Copper SS - 316 Stainless Steel	CJK150 - Cable Joint Kit Elcan - Euro Lite Canister EFL - Frost Lens LED - LED Array

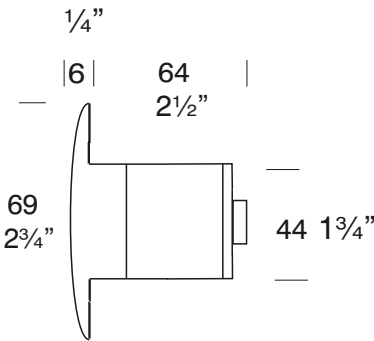

Ordering Example: ESL ss - Euro Step Lite in 316 Stainless Steel.

LED/WH - LED Array in White

(Accessories ordered separately)



FACTORY: Ph: 64-9-528 9471 Fax: 64-9-528 9361.

USA: Ph. 310 560 7310 Fax. 1 877 692 4589.

hunza@hunza.co.nz www.hunza.co.nz

Specifications may change without notice.

130 Felton Mathew Ave, Glen Innes, Auckland, New Zealand.

3237 Long Island St, W. Sacramento, California 95691, USA.

Manufactured in New Zealand.

© 2004 Hunza Holdings Ltd

Ver 1.2

Luminaire Construction

CNC machined from:

Body:

45mm Copper (1¾") rod.

Flange:

70mm (3½") solid copper rod.

Body:

45mm (1¾") 316 Stainless steel rod.

Flange:

70mm (3½") solid 316 stainless steel rod.

Mounting

The Euro Step Lite is fixed in place using a mounting canister. There are no mounting screws in the flange to spoil aesthetics of the luminaire.

Features

Lens:

3mm (1/8") thick clear tempered shatter resistant glass with Hex Cell Louver for glare control.
Life Time Warranty.

Gaskets:

Silicone, iron impregnated 220°C (428°F).

Lamp Holder:

GU4 - 350°C (662°F) ceramic multi contact lamp holder with 250°C (480°F) teflon cables.

Accessories:

Cable Joint Kit (Cat. CJK 50)
Not approved for USA /Canada.

Euro lite Canister (Cat. Elcan)

Frosted Lens (Cat. EFL). LED Array
Red, Blue, White, Yellow,
Green (Cat. LED). Refer sheet 8.4

Standards

IP66



UL1838

Luminaire Weight

Cop .480kg (1lb)

SS .415kg (14oz)

Power Supply

HUNZA® Inground or Wall Mount
Transformer: not included.

LED Refer sheet no.8.4

USA and Canada

HUNZA® Wall Mount Transformer:
not included.

LED Refer sheet no.8.4 :

Lamp Type

Halogen

MR11 GU4 20 watt lamp max.

LED

LED - Refer sheet no. 8.4

USA and Canada

MR11 GU4 10 watt lamp max.

LED

LED - Refer sheet no. 8.4

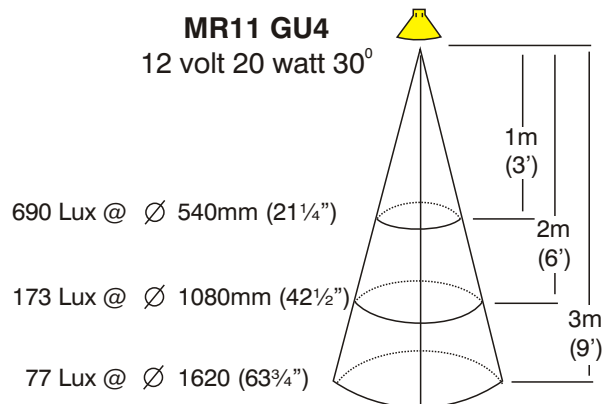
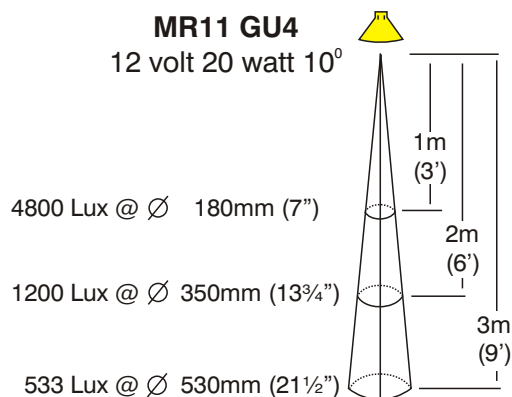

FACTORY: Ph: 64-9-528 9471 Fax: 64-9-528 9361.

USA: Ph. 310 560 7310 Fax. 1 877 692 4589.

hunza@hunza.co.nz www.hunza.co.nz

Specifications may change without notice.

130 Felton Mathew Ave, Glen Innes, Auckland, New Zealand.

3237 Long Island St, W. Sacramento, California 95691, USA.

Manufactured in New Zealand.

Ver 1.2

© 2004 Hunza Holdings Ltd