

Euro Twin Bar Lite

Cat. No. ETBL

[Click here for specifications on this luminaire](#)

[Return to main index](#)



Two individual spot lights which can be aimed in two entirely different directions. Each lite has fully adjustable arms allowing 360 degree rotation and 0 - 90 degree elevation adjustment with built in glare guards.

The heads are mounted on a 250mm (10") bar with twin ground spikes.

Ordering Information

Luminaire Type	Material	Accessories
ETBL - Euro Twin Bar Lite	COP - Copper SS - 316 Stainless Steel	CJK150 - Cable Joint Kit EFL - Frosted Lens /300 - 300mm (12") Spike LED - LED Array

Ordering Example ETBL COP - Euro Twin Bar Lite in Copper

ETBL /300 SS - Euro Twin Bar Lite in 316 Stainless Steel 300mm (12") Spike

EFL - Frosted Lens

(Accessories ordered separately)

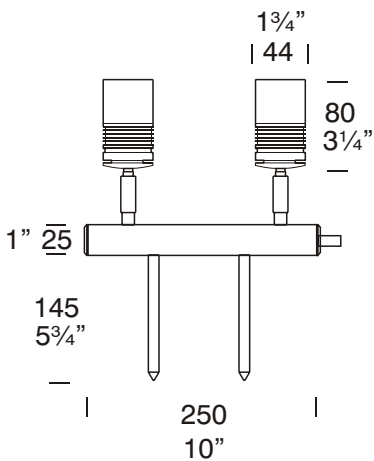

FACTORY: Ph: 64-9-528 9471 Fax: 64-9-528 9361.

USA: Ph. 310 560 7310 Fax. 1 877 692 4589.

hunza@hunza.co.nz www.hunza.co.nz

Specifications may change without notice.

130 Felton Mathew Ave, Glen Innes, Auckland, New Zealand.

3237 Long Island St, W. Sacramento, California 95691, USA.

Manufactured in New Zealand.

© 2004 Hunza Holdings Ltd

Ver 1.2

Luminaire Construction

CNC machined from one of the following metals:

Copper:

Body 45.4mm (1 3/4") rod.

Bar:

25.4mm x 1.42mm (1" x 1/16") tube.

End Cap:

25.4mm x 10 (1" x 3/8") brass rod.

Spike:

11mm x 150mm (3/8" x 6") copper.

316 Stainless Steel :

Body:

45.4mm (13/4") rod.

Bar:

25.4 x 1.42mm (1" x 1/16") tube.

End Cap:

25.4mm x 10 (1" x 3/8") rod.

Spike:

11mm x 150mm (3/8" x 6") rod.

Mounting

Spike 150mm (6") 300mm (12") mounted directly into the ground.

Features

Lens:

3mm (1/8") clear tempered shatter resistant glass with Hex Cell Louver for glare control.

Life Time Warranty.

Gaskets:

Silicone, iron impregnated 220°C (428°F).

Lamp Holders:

GU4 - 350°C (662°F) ceramic multi contact lamp holder with 250°C (480°F) teflon cables.

Accessories:

Cable Joint Kit (Cat. CJK150). Not approved for USA /Canada.

Frosted Lens (Cat. EFL).

Ground Spike 300mm (12")

(Cat. /300).

LED Array Red, Blue, White, Yellow, Green (Cat. LED). Refer sheet 8.4.

Swivels:

Copper luminaires - 360° rotation and 0 - 90° elevation, solid brass with anti rust spring.

Stainless Steel luminaires - 360° rotation and 0 - 90° elevation, full stainless steel construction.

Standards

IP66



UL1838

Luminaire Weight

Cop 2.840kg (6lb 4oz)
SS 2.414kg (5lb 5oz)

Power Supply

HUNZA® Inground or Wall Mount Transformer: not included.

LED - Refer sheet no. 8.4

USA and Canada

HUNZA® Wall Mount Transformer: not included.

LED - Refer sheet no. 8.4

Lamp Type

MR11 GU4 - 2 x 20 watt lamps max

LED - Refer sheet no. 8.4

USA and Canada

MR11 GU4 - 2 x 10 watt lamps max

LED - Refer sheet no. 8.4

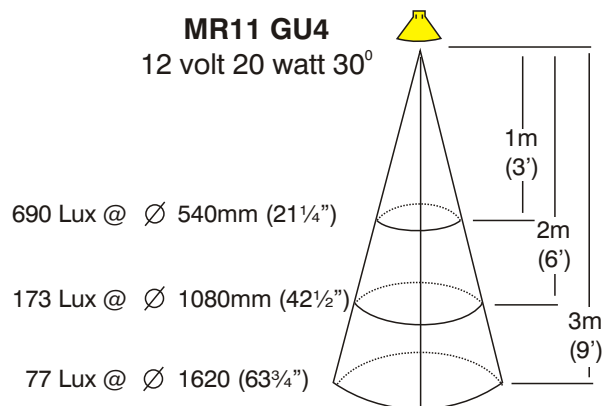
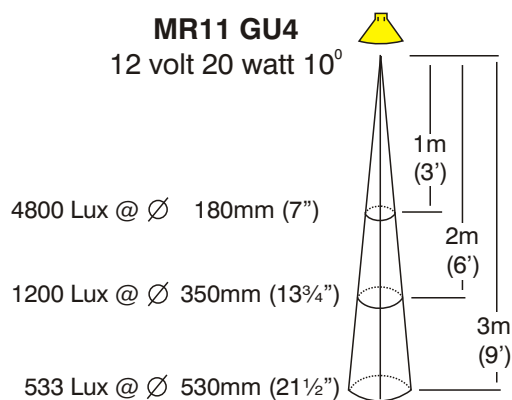

FACTORY: Ph: 64-9-528 9471 Fax: 64-9-528 9361.

USA: Ph. 310 560 7310 Fax. 1 877 692 4589.

hunza@hunza.co.nz www.hunza.co.nz

Specifications may change without notice.

130 Felton Mathew Ave, Glen Innes, Auckland, New Zealand.

3237 Long Island St, W. Sacramento, California 95691, USA.

Manufactured in New Zealand.

© 2004 Hunza Holdings Ltd

Ver 1.2