

# Euro Twin Wall

## Spot

Cat. No. ETWS

Cat. No. ETWS/R

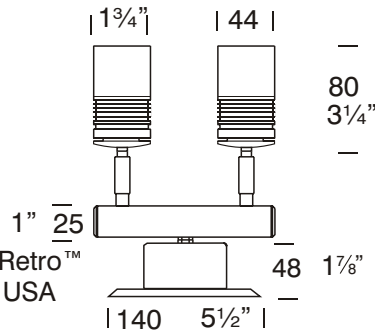
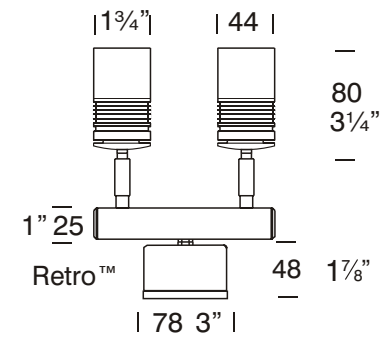
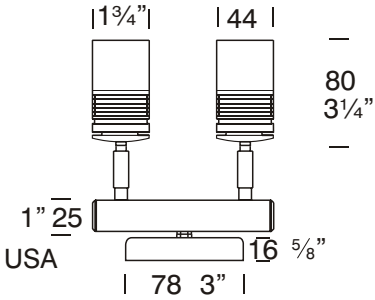
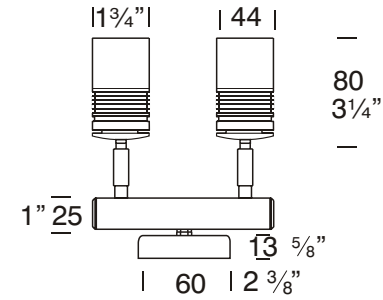

The Euro Twin Wall Spot is for situations where the luminaire needs to be discreet, the smaller sized MR11 lamp is utilised to achieve this. Each spotlight can be aimed in any direction. This luminaire has a fully adjustable arm allowing 360 degree rotation and 0 - 90° elevation with a built in glare guard.

The Retro™ is a 110/240-12 ac mains option suited to an installation where mounting a transformer is a problem, e.g. a brick wall where there is only the cable protruding out of the wall and it is not an option to recess the transformer or when replacing an existing light fitting. The base size increases in size to accommodate the encapsulated IP66 dimmable transformer.

### Ordering Information

#### Luminaire Type

ETWS - Euro Twin Wall Spot

#### Material

Cop - Copper  
SS - 316 Stainless Steel

#### Accessories

EFL - Frost Lens  
CJK150 - CJK150 Cable Joint Kit  
LED - LED Array  
D/LED - LED Driver  
/R - Retro™ Transformer  
110/240-12 volt.  
WBAP - Wall Box Adaptor Plate (12 volt Luminaire)

Ordering Example: ETWS SS - Euro Twin Wall Spot in 316 Stainless Steel  
ETWS/R COP - Euro Twin Wall Spot Retro™ in Copper

CJK150 - Cable Joint Kit  
(Accessories ordered separately)



**FACTORY:** Ph: 64-9-528 9471 Fax: 64-9-528 9361.

**USA:** Ph. 310 560 7310 Fax. 1 877 692 4589.

hunza@hunza.co.nz www.hunza.co.nz

Specifications may change without notice.

130 Felton Mathew Ave, Glen Innes, Auckland, New Zealand.

3237 Long Island St, W. Sacramento, California 95691, USA.

Manufactured in New Zealand.

© 2004 Hunza Holdings Ltd

Ver 1.2

### Luminaire Construction

CNC machined from one of the following metals:

Body:

Copper 45.4mm (13/4") rod.

Base:

Copper Hand spun 2mm (3/16")

Body:

Stainless steel 316 45.4mm (13/4") rod.

Base:

Investment cast and CNC machined.

### Mounting

**12 volt:** the luminaire is mounted to the wall using two 316 stainless screws through a shallow base 16mm (5/8") in depth. A Wall Box Adaptor Plate (Cat. WBAP) is available as an accessory to fit 3.0 and 4.0 junction boxes for USA /Canada.

**Retro™** luminaire (110/240-12 volt): a mounting plate is fixed to the wall using two screws and the luminaire is fitted to the mounting plate.

### Features

#### Lens:

3mm (1/8") thick clear tempered shatter resistant glass with Hex Cell Louver for glare control.

Life Time Warranty.

#### Gaskets:

Silicone, iron impregnated 220°C (428°F).

#### Lamp Holders:

GU4 - 350°C (662°F) ceramic multi contact lamp holder with 180°C (356°F) silicone cables.

#### Accessories:

Cable Joint Kit (Cat. CJK 150)  
Not approved for USA /Canada.

Frost Lens (Cat. EFL).

LED Array Red, Blue, White, Yellow, Green (Cat. LED). Refer sheet 8.4

LED Driver (Cat. D/LED) Refer sheet no. 8.4

Retro™ transformer 110/240-12 volt (Cat. /R).

Wall Box Adaptor Plate (Cat. WBAP 12 volt luminaires USA/Canada).

#### Swivel:

Copper luminaires - 360° rotation and 0 - 90° elevation, solid brass with anti rust spring.

Stainless Steel luminaires - 360° rotation and 0 - 90° elevation, full stainless steel construction.

### Standards

**IP66 AS/NZS 61046**



**UL1838**

**Luminaire Weight**  
**12 volt**

Cop 1.445kg (3lb 2oz)

SS 1.245kg (2lb 11oz)

**Retro™**

Cop 2.006kg (4lb 6oz)

SS 1.730kg (3lb 13oz)

### Power Supply

HUNZA® Inground or Wall Mount Transformer: not included.

**LED** - Refer sheet no. 8.4

#### USA and Canada

HUNZA® Wall Mount Transformer: not included.

**LED** - Refer sheet no. 8.4

### RETRO™

HUNZA® 110/240-12 volt ac silicone encapsulated electronic transformer built into the Retro™ base.

Dimmable with a suitable dimmer.  
\* Note see page 7.4 for details.

### Lamp Type

MR11 GU4 - 2 x 20 watt lamp max.

**LED** - Refer sheet no. 8.4

#### USA and Canada

MR11 GU4 - 2 x 10 watt lamp max.

**LED** - Refer sheet no. 8.4

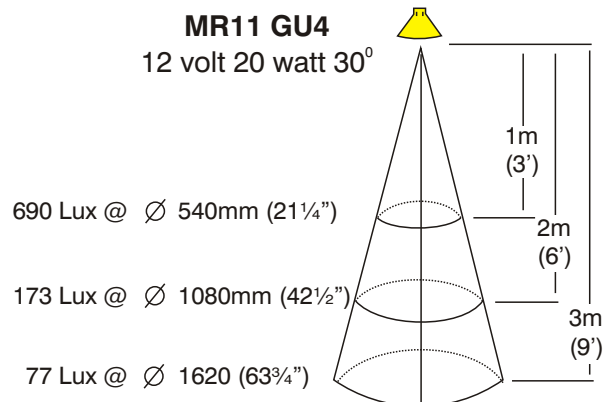
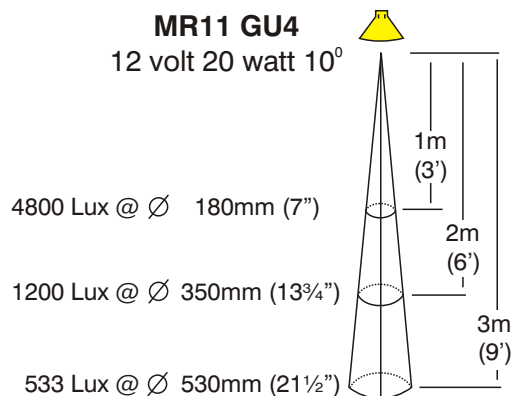

**FACTORY:** Ph: 64-9-528 9471 Fax: 64-9-528 9361.

**USA:** Ph. 310 560 7310 Fax. 1 877 692 4589.

hunza@hunza.co.nz www.hunza.co.nz

Specifications may change without notice.

130 Felton Mathew Ave, Glen Innes, Auckland, New Zealand.

3237 Long Island St, W. Sacramento, California 95691, USA.

Manufactured in New Zealand.

Ver 1.2

© 2004 Hunza Holdings Ltd