

Euro Wall Down Lite

Cat. No. EDL
Cat. No. EDL/R

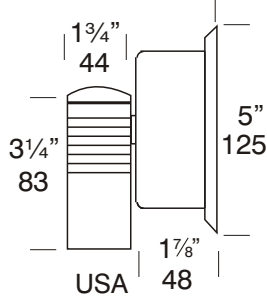
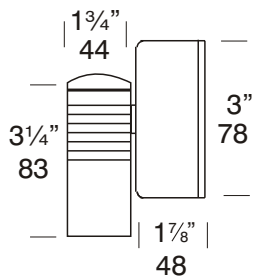
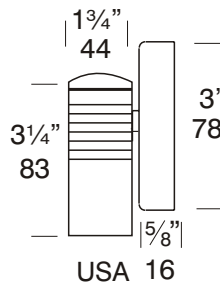
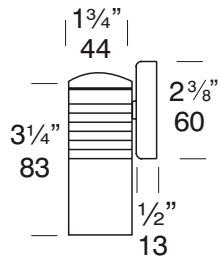

Suitable for mounting on timber, masonry, stone, etc. Non adjustable for one way wall washing, can be mounted with the lamp directed up or down. Water resistant with a 60mm, (USA 3") diameter mounting base, complete with stainless steel screws.

The Retro™ is a 110/240-12 ac mains option suited to an installation where mounting a transformer is a problem, e.g. a brick wall where there is only the cable protruding out of the wall and it is not an option to recess the transformer or when replacing an existing light fitting. The base size increases in size to accommodate the encapsulated IP66 dimmable transformer.

Ordering Information

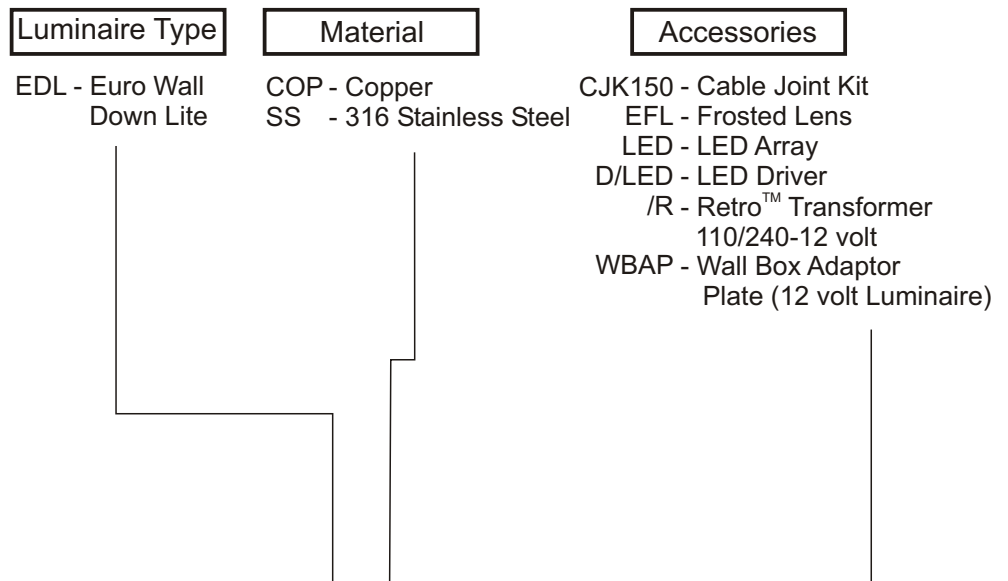

Ordering Example EDL COP - Euro Wall Down Lite in Copper
EDL/RSS - Euro Wall Down Lite Retro™ in 316 Stainless Steel
WBAP - Wall Box Adaptor

(Accessories ordered separately)



FACTORY: Ph: 64-9-528 9471 Fax: 64-9-528 9361.
USA: Ph. 310 560 7310 Fax. 1 877 692 4589.
hunza@hunza.co.nz www.hunza.co.nz
Specifications may change without notice.

130 Felton Mathew Ave, Glen Innes, Auckland, New Zealand.
3237 Long Island St, W. Sacramento, California 95691, USA.
Manufactured in New Zealand.

Ver 1.2

© 2004 Hunza Holdings Ltd

Luminaire Construction

CNC machined from one of the following metals:

Body:

Copper 45.4mm (13/4") rod.

Base:

Copper Hand spun 2mm (3/16")

Body:

Stainless steel 316 45.4mm (13/4") rod.

Base:

Investment cast and CNC machined.

Mounting

12 volt: the luminaire is mounted to the wall using two 316 stainless screws through a shallow base 16mm (5/8") in depth. A Wall Box Adaptor Plate (Cat. WBAP) is available as an accessory to fit 3.0 and 4.0 junction boxes for USA /Canada.

Retro™ luminaire (110/240-12 volt): a mounting plate is fixed to the wall using two screws and the luminaire is fitted to the mounting plate.

Features

Lens:

3mm (1/8") thick clear tempered shatter resistant glass with Hex Cell Louver for glare control.

Life Time Warranty.

Gaskets:

Silicone, iron impregnated 220°C (428°F).

Lamp Holder:

GU4 - 350°C (662°F) ceramic multi contact lamp holder with 180°C (356°F) silicone cables.

Accessories:

Cable Joint Kit (Cat. CJK 150)
Not approved for USA /Canada.

Frost Lens (Cat. EFL).

LED Array Red, Blue, White, Yellow, Green (Cat. LED). Refer sheet 8.4.

LED Driver (Cat. D/LED). Refer sheet 8.4.

Retro™ transformer 110/240-12 volt (Cat. /R).

Wall Box Adaptor Plate (Cat. WBAP)
12 volt luminaires USA/Canada).

Standards

IP66 AS/NZS 61046



UL1838

Luminaire Weight

12 volt

Cop .465kg (1lb)

SS .480kg (1lb 1oz)

Retro™

Cop .960kg (2lb 1oz)

SS 1.035kg (2lb 4oz)

Power Supply

HUNZA® Inground or Wall Mount Transformer: not included.

LED - Refer sheet no. 8.4

USA and Canada

HUNZA® Wall Mount Transformer: not included

LED - Refer sheet no. 8.4

RETRO™

HUNZA® 110/240-12 volt ac silicone encapsulated electronic transformer built into the Retro™ base.

Dimmable with a suitable dimmer.

*Note see page 7.4 for details.

Lamp Type

MR11 GU4 - 1 x 20 watt lamp max.

LED - Refer sheet 8.4

USA and Canada

MR11 GU4 - 1 x 10 watt lamp max.

LED - Refer sheet 8.4

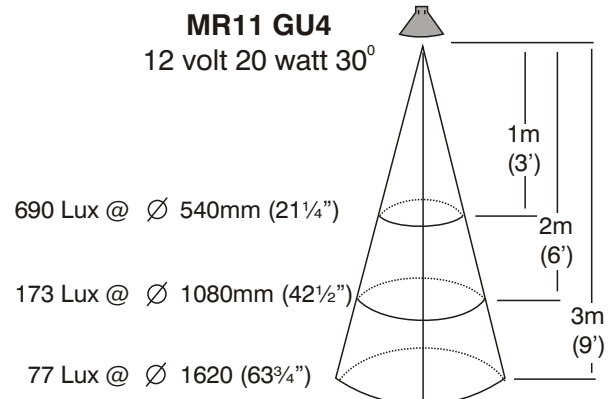
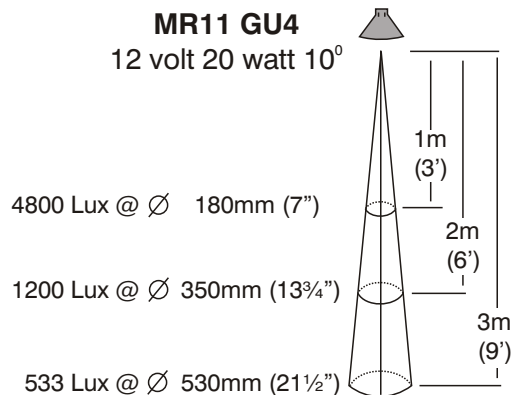

FACTORY: Ph: 64-9-528 9471 Fax: 64-9-528 9361.

USA: Ph. 310 560 7310 Fax. 1 877 692 4589.

hunza@hunza.co.nz www.hunza.co.nz

Specifications may change without notice.

130 Felton Mathew Ave, Glen Innes, Auckland, New Zealand.

3237 Long Island St, W. Sacramento, California 95691, USA.

Manufactured in New Zealand.

Ver 1.2

© 2004 Hunza Holdings Ltd