

Floor Lite Dark Lighter

Cat. No. FLdk

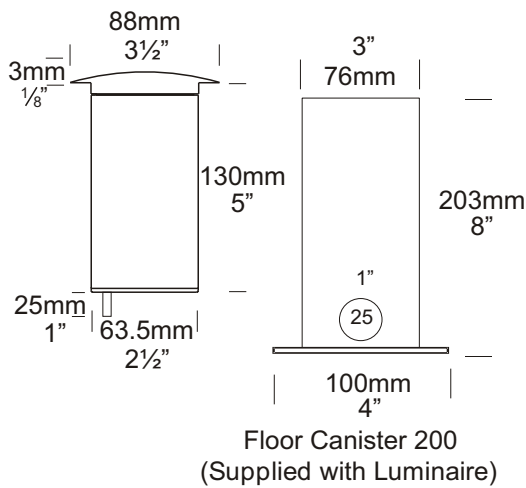

The Floor Lite Dark Lighter has a lamp that is recessed 50mm (2") down in to the body of the luminaire, along with a hex cell louvre and a matt black interior the luminaire has superior glare control. The Dark Lighter version of the Floor Lite has an extremely low profile (3mm) and can be walked upon with out damaging the luminaire. There are five flange designs: Clover, Cross, Grill, Louvre, (45 degree angle), Spot and is supplied with a mounting canister.



Ordering Information

Luminaire Type

FLdk - Floor Lite

Material

316 Stainless Steel

Accessories

CJK150 - Cable Joint Kit
Canss - 316 Stainless Steel Canister
LENSSTEPF - Frost Lens
Dkcan - Deck Canister
FLcan200 - Floor Lite Canister

For an alternative LED option start at page 10.4

Flange

CL - Clover
CR - Cross
GR - Grill
LU - Louvre
SP - Spot

Ordering Example: FLdk GRss - Floor Lite Grill in 316 Stainless Steel



HUNZA™ PURE
OUTDOOR
LIGHTING

HUNZA FACTORY
130 Felton Mathew Ave
Glen Innes
Auckland 1072
New Zealand

Ph: 64-9-528 9471
Fax: 64-9-528 9361
hunza@hunza.co.nz
www.hunza.co.nz

INTERNATIONAL CONTACTS:
www.hunza.co.nz/contacts.php

Specifications may change without notice.
Manufactured in New Zealand.
© 2009 Hunza Holdings Ltd.

Ver 1.4

Luminaire Construction

CNC machined from:

Body:

316 Stainless Steel 63.5mm (2½") x 9mm (1/3"). End cap - solid 316 stainless steel 63.5mm (2½") rod.

Flange:

316 Stainless Steel 90mm (3½").

Mounting

The luminaire is pushed into the canister and is held by two silicone "O" rings: Canss, FLcan, Flucan: Cast into concrete, brick, concrete block, etc.

Dkcan: mounted into wooden decks, wooden frames, etc.

Features

Lens:

10mm (3/8") clear flush fit shatter resistant glass.

Life Time Warranty.

Gasket:

Silicone, iron impregnated 220°C (428°F).

Lamp Holders:

GU5.3 - 350°C (662°F) ceramic multi contact lamp holder with 250°C (480°F) teflon cables.

Accessories:

Cable Joint Kit (Cat. CJK150)
Not approved for USA/Canada.
Deck Canister (Cat. Dkcan).
Frosted Lens (Cat. LENSSTEPF).
Floor Canister 200 (Cat. FLcan200).
316 Stainless Canister for use in lime stone etc. (Cat. Canss).

Standards

EN60598

IP66/IP68



UL1838

Luminaire Weight

SS 1.630kg (3lb 10oz)

Power Supply

HUNZA™ Inground or Wall Mount Transformer: not included.

USA and Canada:

HUNZA™ Wall Mount Transformer: not included.

Luminaire: supplied with

MR16 GU5.3 - 20 watt lamp max.

LED - Refer sheet no. 10.4

USA and Canada:

MR16 GU5.3 20 watt lamp max.

LED - Refer sheet no. 10.4.

MR16 ESX GU5.3
12 volt 20 watt 10°

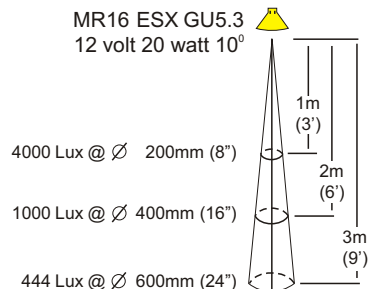

MR16 BAB GU5.3
12 volt 20 watt 38°

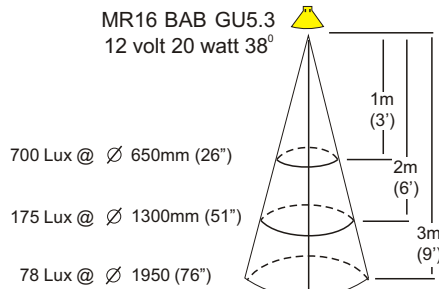

MR16 GU5.3
12 volt 20 watt 60°

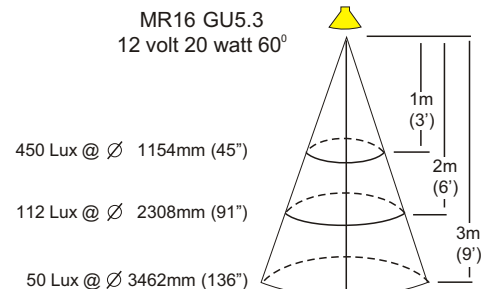

These diagrams refer to the Spot Lite Flange (D) only.

HUNZA™ PURE
OUTDOOR
LIGHTING

HUNZA FACTORY
130 Felton Mathew Ave
Glen Innes
Auckland 1072
New Zealand

Ph: 64-9-528 9471
Fax: 64-9-528 9361
hunza@hunza.co.nz
www.hunza.co.nz

INTERNATIONAL CONTACTS:
www.hunza.co.nz/contacts.php

Specifications may change without notice.
Manufactured in New Zealand.

© 2009 Hunza Holdings Ltd.

Ver 1.4