

Floor Lite Square

Cat. No. FLsq

Cat. No. FLsqfl

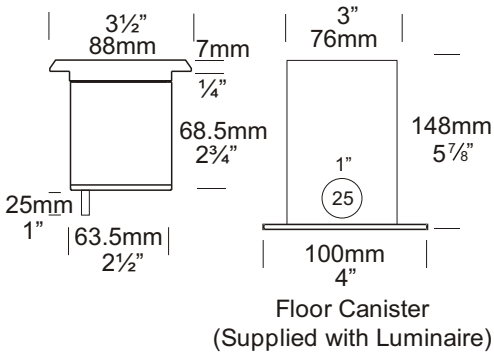

The Floor Lite Square has a 88mm x 88mm (3 1/2" x 3 1/2") flange and has a low profile of 7mm. The square shape makes it ideal for mounting in tiled areas and it can be walked upon without being damaged. There are five flange designs: Clover, Grill, Louvre (45 degree angle), Spot, Cross and is supplied with a mounting canister.

A 110/240 volt fluorescent option is available which offers excellent light output, low energy usage and very low heat generation, this changes the luminaire to an IP66 rating.

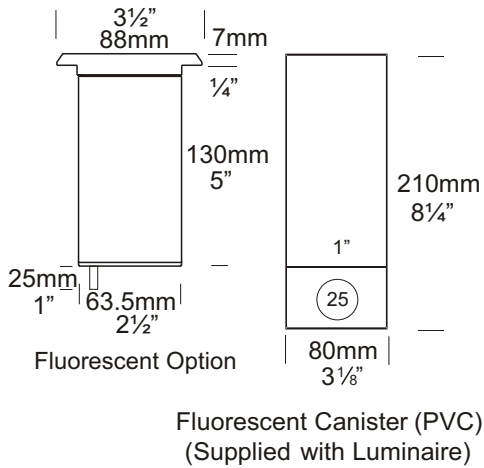

Ordering Information

Luminaire Type	Material	Accessories
FLsq - Floor Lite Square	316 Stainless Steel	CJK150 - Cable Joint Kit Canss - 316 Stainless Steel Canister LENSSTEPF - Frost Lens Dkcan - Deck Canister FLcan - Floor Lite Canister FL - Fluorescent Option Flucan - Fluorescent Canister HCL - Hex Cell Adaptor For an alternative LED option start at page 10.4
Flange		
CL - Clover (A) CR - Cross (E) GR - Grill (B) LU - Louvre (C) SP - Spot (D)		



Ordering Example: FL LUsqss - Floor Lite Louvre (C) Square in 316 Stainless Steel

FLSPsqflss - Floor Lite Spot (D) Square in 316 Stainless Steel with fluorescent option

FL - Fluorescent Option 240 volt 8watt
(Accessories ordered separately)

HUNZA™ PURE OUTDOOR LIGHTING

HUNZA FACTORY
130 Felton Mathew Ave
Glen Innes
Auckland 1072
New Zealand

Ph: 64-9-528 9471
Fax: 64-9-528 9361
hunza@hunza.co.nz
www.hunza.co.nz

INTERNATIONAL CONTACTS:
www.hunza.co.nz/contacts.php
Specifications may change without notice.
Manufactured in New Zealand.
© 2009 Hunza Holdings Ltd.

Ver 1.4

Luminaire Construction

CNC machined from:

Body:

316 Stainless Steel 63.5mm (2½") x 9mm (11/32"). End cap - solid 316 stainless steel 63.5mm (2½") rod.

Flange:

90mm x 90mm (3½" x 3½") solid 316 stainless steel bar.

Mounting

The luminaire is pushed into the canister and is held by two silicone "O" rings: Canss, FLcan, FLucan are cast into concrete, brick, concrete block, etc.

Dkcan: Mounted into wooden decks, wooden frames, etc.

Features

Lens:

3mm (1/8") clear tempered shatter resistant glass.

Life Time Warranty.

Gasket:

Silicone, iron impregnated 220°C (428°F).

Lamp Holders:

GU5.3 - 350°C (662°F) ceramic multi contact lamp holder with 250°C (480°F) teflon cables.

Fluorescent:

E27 PET 210°C (410°F) base mount. E26 available in the USA.

Accessories:

Cable Joint Kit (Cat. CJK150)
Not approved for USA/Canada.

Deck Canister (Cat. Dkcan).

Frosted Lens (Cat. LENSSTEPF).

Floor Canister (Cat. Flcan).

Fluorescent Canister PVC (Cat. Flucan).

Fluorescent Option 8watt 240 volt (Cat. FL) IP66.

Hex Cell Louvre Adaptor (Cat. HCL)
(Note: Supplied as standard for USA/Canada).

316 Stainless Canister for use in lime stone etc. (Cat. Canss).

Standards

EN60598

IP66/IP68



UL1838

Luminaire Weight

SS 1.175kg (2lb 9oz)

Fluorescent IP66

SS 1.810kg (3lb 15oz)

Power Supply

HUNZA™ Inground or Wall Mount
Transformer: not included.

USA and Canada:

HUNZA™ Wall Mount Transformer:
not included.

Luminaire: supplied with

MR16 GU5.3 - 20 watt lamp max.

Fluorescent

E27 - 110/240 volt self ballasted
lamp.

LED - Refer sheet no. 10.4

USA and Canada:

MR16 GU5.3 20 watt lamp max.

LED - Refer sheet no. 10.4.

MR16 ESX GU5.3
12 volt 20 watt 10°

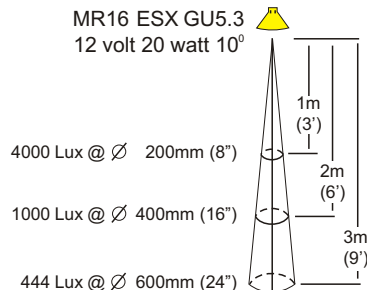

MR16 BAB GU5.3
12 volt 20 watt 38°

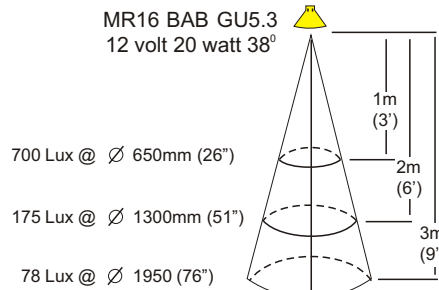

MR16 GU5.3
12 volt 20 watt 60°

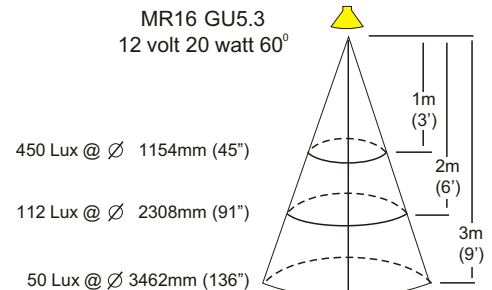

These diagrams refer to the Spot Lite Flange (D) only.

HUNZA™ PURE
OUTDOOR
LIGHTING

HUNZA FACTORY
130 Felton Mathew Ave
Glen Innes
Auckland 1072
New Zealand

Ph: 64-9-528 9471
Fax: 64-9-528 9361
hunza@hunza.co.nz
www.hunza.co.nz

INTERNATIONAL CONTACTS:
www.hunza.co.nz/contacts.php

Specifications may change without notice.
Manufactured in New Zealand.

© 2009 Hunza Holdings Ltd.

Ver 1.4