

# Floor Lite

Cat. No. FL

Cat. No. FLfl

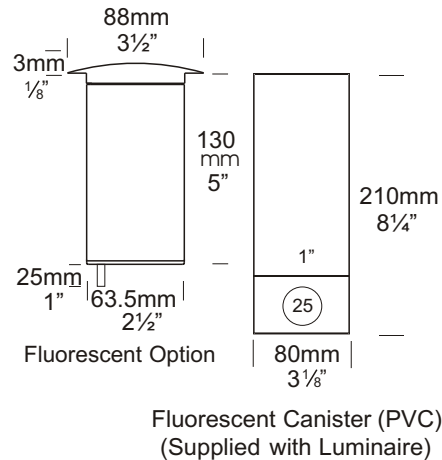
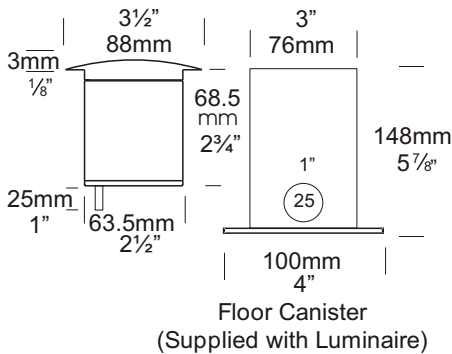

The Floor Lite has an extremely low profile (3mm) and can be walked upon without damaging the luminaire. There are five flange designs: Clover, Grill, Louvre (45 degree angle), Spot, Cross and is supplied with a mounting canister.

A 110/240 volt fluorescent option is available which offers excellent light output, low energy usage and very low heat generation, this changes the luminaire to an IP66 rating.

## Ordering Information

Luminaire Type

Material

Accessories

FL - Floor Lite

316 Stainless Steel

CJK150 - Cable Joint Kit

Canss - 316 Stainless Steel Canister

LENSSTEPF - Frost Lens

Dkcan - Deck Canister

FLcan - Floor Lite Canister

FL - Fluorescent Option

Flucan - Fluorescent Canister

HCL - Hex Cell Adaptor

For an alternative LED option start at page 10.4

Flange

CL - Clover (A)

CR - Cross (E)

GR - Grill (B)

LU - Louvre (C)

SP - Spot (D)

Ordering Example:

FL LUss - Floor Lite Louvre (C)  
316 Stainless Steel

FL SPflss - Floor Lite in 316 Stainless Steel  
Spot (D) with fluorescent option

(Accessories ordered separately)

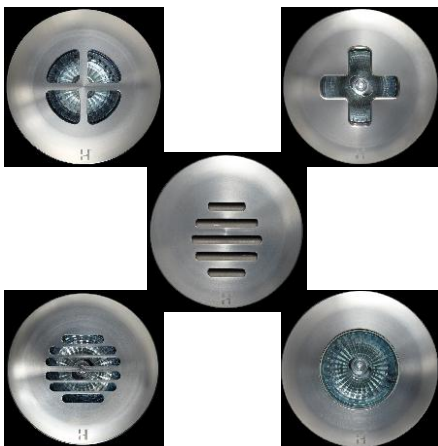

**HUNZA**™ PURE  
OUTDOOR  
LIGHTING

**HUNZA FACTORY**  
130 Felton Mathew Ave  
Glen Innes  
Auckland 1072  
New Zealand

Ph: 64-9-528 9471  
Fax: 64-9-528 9361  
hunza@hunza.co.nz  
www.hunza.co.nz

**INTERNATIONAL CONTACTS:**  
www.hunza.co.nz/contacts.php  
Specifications may change without notice.  
Manufactured in New Zealand.  
© 2009 Hunza Holdings Ltd.

Ver 1.4

## Luminaire Construction

CNC machined from:

### Body:

316 Stainless Steel 63.5mm (2½") x 9mm (11/32"). End cap - solid 316 stainless steel 63.5mm (2½") rod.

### Flange:

316 Stainless Steel 90mm (3½").

## Mounting

The luminaire is pushed into the canister and is held by two silicone "O" rings: Canss, FLcan, Flucan: Cast into concrete, brick, concrete block, etc.

Dkcan: mounted into wooden decks, wooden frames, etc.

## Features

### Lens:

3mm (1/8") clear tempered shatter resistant glass.

Life Time Warranty.

### Gasket:

Silicone, iron impregnated 220°C (428°F).

### Lamp Holders:

GU5.3 - 350°C (662°F) ceramic multi contact lamp holder with 250°C (480°F) teflon cables.

### Fluorescent:

E27 PET 210°C (410°F) base mount. E26 available in the USA.

### Accessories:

Cable Joint Kit (Cat. CJK150)

Not approved for USA /Canada.

Deck Canister (Cat. Dkcan).

Frosted Lens (Cat. LENSSTEPF).

Floor Canister (Cat. Flcan).

Fluorescent Canister PVC (Cat. Flucan).

Fluorescent Option 8watt 240 volt (Cat. FL) IP66.

Hex Cell Louvre Adaptor (Cat. HCL) (Note: Supplied as standard for USA/Canada).

316 Stainless Canister for use in lime stone etc. (Cat. Canss).

## Standards

EN60598

IP66/IP68



UL1838

## Luminaire Weight

SS .995kg (2lb 3oz)

Fluorescent IP66

SS 1.630kg (3lb 10oz)

## Power Supply

HUNZA™ Inground or Wall Mount Transformer: not included.

USA and Canada:

HUNZA™ Wall Mount Transformer: not included.

Luminaire: supplied with

MR16 GU5.3 - 20 watt lamp max.

**LED** - Refer sheet no. 10.4  
Fluorescent

E27 - 110/240 volt self ballasted lamp.

USA and Canada:

MR16 GU5.3 20 watt lamp max.

**LED** - Refer sheet no. 10.4.

MR16 ESX GU5.3  
12 volt 20 watt 10°

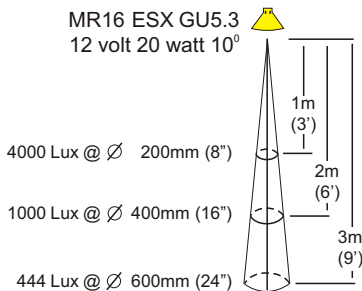

MR16 BAB GU5.3  
12 volt 20 watt 38°

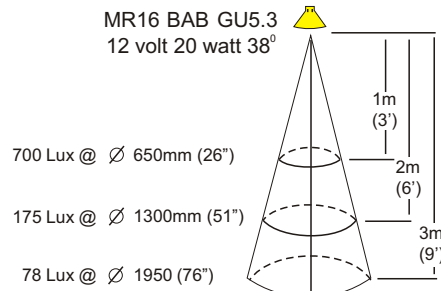

MR16 GU5.3  
12 volt 20 watt 60°

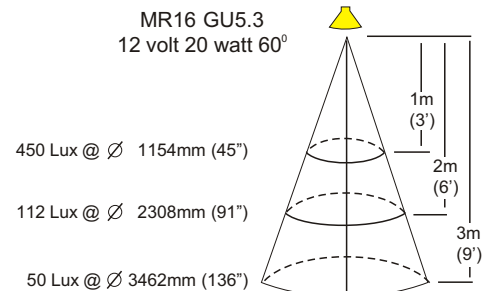

These diagrams refer to the Spot Lite Flange (D) only.

**HUNZA™** PURE  
OUTDOOR  
LIGHTING

**HUNZA FACTORY**  
130 Felton Mathew Ave  
Glen Innes  
Auckland 1072  
New Zealand

Ph: 64-9-528 9471  
Fax: 64-9-528 9361  
hunza@hunza.co.nz  
www.hunza.co.nz

**INTERNATIONAL CONTACTS:**  
www.hunza.co.nz/contacts.php

Specifications may change without notice.  
Manufactured in New Zealand.

© 2009 Hunza Holdings Ltd.

Ver 1.4