

Pillar Lite

Cat. No. PIL

Cat. No. PIL/R

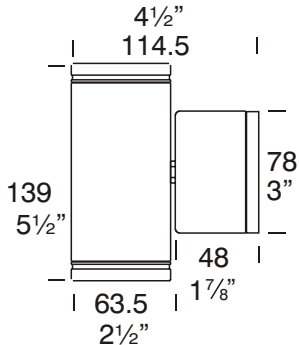
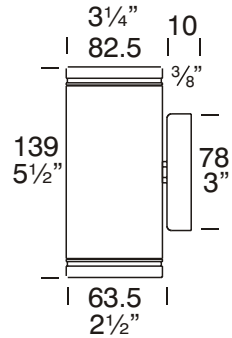

Retro™

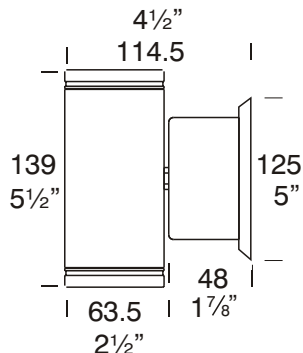

Retro™

USA / CANADA



RETRO VERSION SHOWN

The Pillar Lite illuminates both upwards and downwards, giving columns, gateway pillars and entrances a dramatic effect.

The Retro™ is a 110/240-12 ac mains option suited to an installation where mounting a transformer is a problem, e.g. a brick wall where there is only the cable protruding out of the wall and it is not an option to recess the transformer or when replacing an existing light fitting. The base size increases in size to accommodate the encapsulated IP66 dimmable transformer.

Ordering Information

Luminaire Type

PIL - Pillar Lite

Material/Finish

BK - Black
 BZ - Bronze
 GN - Green
 MS - Metallic Silver
 WH - White

COP - Copper
 SS - 316 Stainless Steel

Accessories

CJK150 - Cable Joint Kit
 DFL - Frosted Lens
 GG - Glare Guard
 HCL - Hex Cell Louvre Adaptor
 LED - LED Array
 D/LED - LED Driver
 /R - Retro™ Transformer
 110/240-12 volt
 WBAP - Wall Box Adaptor Plate

Ordering Example PIL COP - Pillar Lite in Copper
 PIL/R GN - Pillar Lite Retro in Green

HCL BK - Hex Cell Louvre Adaptor in Black
 (Accessories ordered separately)

Patent Pending



FACTORY: Ph: 64-9-528 9471 Fax: 64-9-528 9361.

USA: Ph. 310 560 7310 Fax. 1 877 692 4589.

hunza@hunza.co.nz www.hunza.co.nz

Specifications may change without notice.

130 Felton Mathew Ave, Glen Innes, Auckland, New Zealand.

3237 Long Island St, W. Sacramento, California 95691, USA.

Manufactured in New Zealand.

Ver 1.2

© 2004 Hunza Holdings Ltd

Luminaire Construction

CNC machined from one of the following metals:

Body: High corrosion resistant low copper 63.5mm (2½") x 10mm (25/64") aluminium.

Base & Mounting Plate: Cast from virgin high corrosion resistant CC401 low copper aluminium alloy chromate substrate and high UV resistant polyester powder coat - Black, Bronze, Green, Metallic Silver, White.

Body: Copper 63.5mm (2½") x 10mm (25/64).

Base: Copper Hand spun 2mm (5/64")

Mounting Plate: Forged brass (Retro™)

Body: 316 Stainless steel 63.5mm (2½") x 9mm (11/32") rod.

Base: Investment cast and CNC machined. (Retro™)

Mounting Plate: Investment cast and CNC machined.

Mounting

12 volt: the luminaire is mounted to the wall using two 316 stainless screws through a shallow base 16mm (5/8") in depth. A Wall Box Adaptor Plate (Cat. WBAP) is available as an accessory to fit 3.0 and 4.0 junction boxes for USA /Canada.

Retro™ luminaire (110/240-12 volt): a mounting plate is fixed to the wall using two screws and then the luminaire is fixed to the mounting plate.

Features

Lens:

3mm (1/8") thick clear tempered shatter resistant glass.

Life Time Warranty.

Gaskets:

Silicone, iron impregnated 220°C (428°F)

Lamp Holders:

GU5.3 - 350°C (662°F) ceramic multi contact lamp holder with 250°C (480°F) teflon cables.

Accessories:

CJK150 Cable Joint Kit (Cat. CJK150)
Not approved for USA /Canada.

Frosted Lenses (Cat. DFL)

Glare Guards (Cat. GG)

Hex Cell Louvre Adaptors (Cat. HCL)

LED Array Red, Blue, White, Yellow, Green (Cat. LED). Refer sheet 8.4

LED Driver (Cat. D/LED) Refer sheet no. 8.4

Retro™ Transformer 110/240-12 volt (Cat. /R).

Wall Box Adaptor Plate (Cat. WBAP)
12 volt luminaire USA / Canada)

Standards

IP66 AS/NZS61046



UL1838

Luminaire Weight

12 volt

Alum .775kg (1lb 11oz)
Cop 2.230kg (4lb 14oz)
SS 1.750kg (3lb 13oz)

Retro™

Alum 1.100kg (21lb 6oz)
Cop 2.650kg (5lb 13oz)
SS 2.200kg (4lb 13oz)

Power Supply

12 volt

HUNZA® Inground or HUNZA® Wall Mount Transformer: not included.

LED - Refer sheet no. 8.4

USA/ Canada

HUNZA® Wall Mount Transformer: not included.

Approved for internal use.

LED - Refer sheet no. 8.4

RETRO™

HUNZA 110/240-12 volt ac silicone encapsulated electronic transformer built into the Retro™ base.

Dimmable with a suitable dimmer.

Approved for internal use.

* Note see page 7.4 for details.

Luminaire: supplied with

MR16 GU5.3 2 x 20 watt lamps max.

LED - Refer sheet no. 8.4

USA and Canada:

MR16 GU5.3 2 x 20 watt lamps max.

LED - Refer sheet no. 8.4

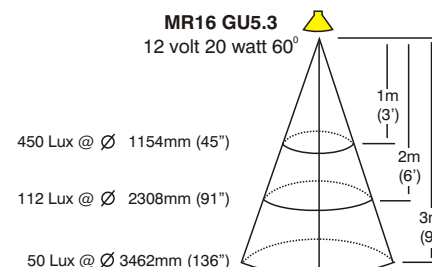
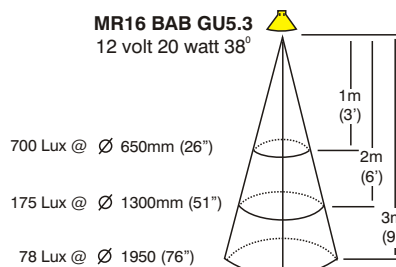
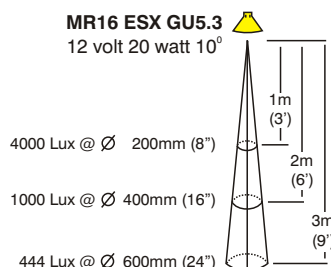

FACTORY: Ph: 64-9-528 9471 Fax: 64-9-528 9361.

USA: Ph. 310 560 7310 Fax. 1 877 692 4589.

hunza@hunza.co.nz www.hunza.co.nz

Specifications may change without notice.

130 Felton Mathew Ave, Glen Innes, Auckland, New Zealand.

3237 Long Island St, W. Sacramento, California 95691, USA.

Manufactured in New Zealand.

© 2004 Hunza Holdings Ltd

Ver 1.2