

Step Lite Eyelid

Cat. No. SLE
Cat. No. SLEfl

[Click here for specifications on this luminaire](#)

[Return to main index](#)



Eyelid Step Lite eliminates all upward light. When using stairs there is no blinding glare or sparkle from the lamp to irritate the eyes. The eyelid is secured to the flange by two screws. When a canister is used there are no mounting holes in the flange.

A 240 volt fluorescent option is available which offers excellent light output, low energy usage and very low heat generation, this changes the luminaire to an IP66 rating.

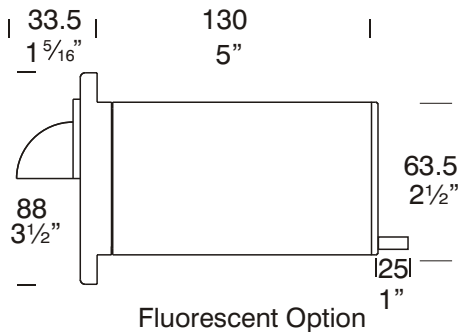
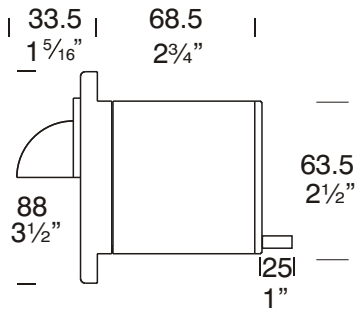

Ordering Information

Luminaire Type	Material/Finish	Accessories
SLE - Step Lite Eyelid	BK - Black BZ - Bronze GN - Green WH - White MS - Metallic Silver COP - Copper	CJK150 - Cable Joint Kit DFL - Frosted Lens FL - Fluorescent Option HCL - Hex Cell Louvre Adaptor LED - LED Array D/LED - LED Driver Canss - 316 Stainless Steel Canister Flucan - Fluorescent Canister Sican - Step Lite Canister

Ordering Example

SLEfl COP - Step Lite Eyelid in Copper with Fluorescent Option.

HCL MS - Hex Cell Louvre in Metallic Silver
(Accessories ordered separately)



FACTORY: Ph: 64-9-528 9471 Fax: 64-9-528 9361.
USA: Ph. 310 560 7310 Fax. 1 877 692 4589.
hunza@hunza.co.nz www.hunza.co.nz
Specifications may change without notice.

130 Felton Mathew Ave, Glen Innes, Auckland, New Zealand.
3237 Long Island St, W. Sacramento, California 95691, USA.
Manufactured in New Zealand.

Ver 1.2

© 2004 Hunza Holdings Ltd

Luminaire Construction

CNC machined from one of the following metals:

High corrosion resistant 63.5mm (2½") x 10mm (25/64") aluminium.
End cap - solid aluminium 63.5mm (2½") rod, flange 90mm (3½") solid aluminium rod with chromate substrate and high UV resistant polyester powder coat -

Colours Black, Bronze, Green, Metallic Silver, White.

Copper: 63.5mm (2½") x 10mm (13/32"). End cap - solid copper 63.5mm (2½") rod.
Flange 90mm (3½") solid copper rod.

Mounting

Designed to fit through a 66mm (2 5/8") hole and be fixed into position by two screws in the flange or a Step Lite canister (see accessories) can be used which maintains the aesthetic look of the flange by eliminating the two screw holes in the flange.

Features

Lens:
3mm (1/8") thick clear tempered shatter resistant glass.
Life Time Warranty.

Gaskets:
Silicone, iron impregnated 220°C (428°F).

Lamp Holders:
GU5.3 - 350°C (662°F) ceramic multi contact lamp holder with 250°C (480°F) teflon cables.

Fluorescent
E27 PET 210° (410°F) base mount.

Accessories:

Cable Joint Kit (Cat. CJK 50)
Not approved for USA /Canada.

Fluorescent Option 5 watt 240 volt (Cat. FL) IP66.

Frosted Lens (Cat. DFL).

Hex Cell Louvre Adaptor (Cat. HCL).

LED Array Red, Blue, White, Yellow, Green (Cat. LED). Refer sheet 8.4

LED Driver (Cat. D/LED) Refer sheet no. 8.4

Step Canister (Cat. Slcan).

Fluorescent Canister, PVC (Cat. Flucan).

316 Stainless Canister for use in lime stone etc. (Cat. Canss).

Standards

IP66 / IP68



UL1838

Luminaire Weight

12 volt
Alum .465kg (1lb)
Cop 1.340kg (2lb 15oz)
SS 1.055kg (2lb 5oz)

Fluorescent IP66
Alum .780kg (1lb 11oz)
Cop 2.275kg (5lb)
SS 1.690kg (3lb 11oz)

Power Supply

HUNZA® Inground or Wall Mount
Transformer: not included.
LED - Refer sheet no. 8.4

USA and Canada:
HUNZA® Wall Mount Transformer:
not included.
LED - Refer sheet no. 8.4

Luminaire: supplied with Halogen
MR16 GU5.3 20 watt lamp max.
Fluorescent
E27 - 240 volt 5 watt self ballasted lamp.
LED
LED - Refer sheet no. 8.4

USA and Canada:
MR16 GU5.3 20 watt lamp max.
LED
LED - Refer sheet no. 8.4

Step Lite Eyelid MR16 BAB 20 watt lamp - Lens height 400mm (15¾")

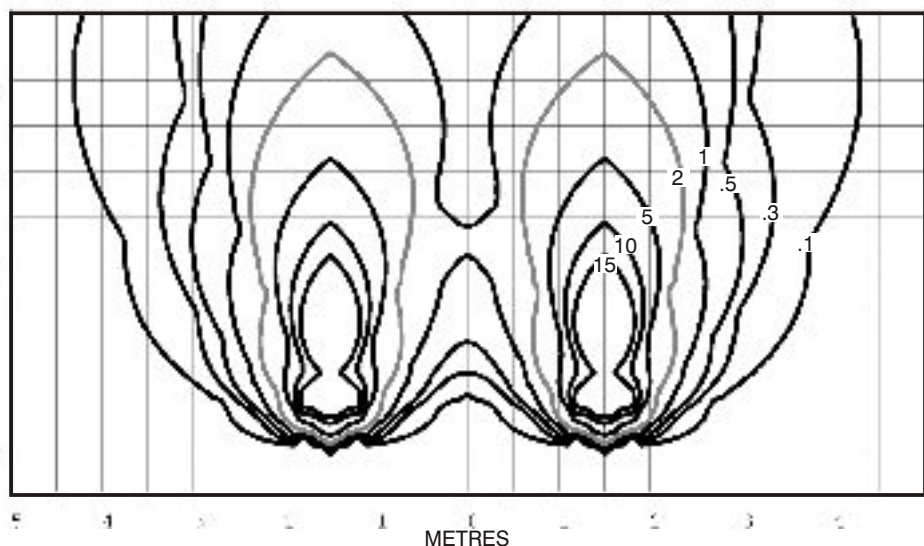
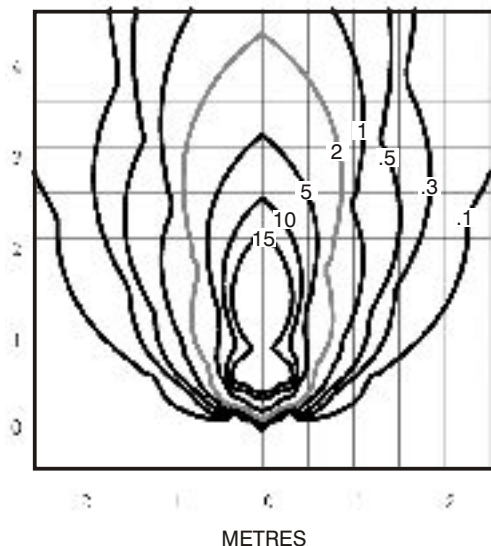

Isolux Lumens Plot - Footcandles = Isolux figures divided by 10.76



FACTORY: Ph: 64-9-528 9471 Fax: 64-9-528 9361.

USA: Ph. 310 560 7310 Fax. 1 877 692 4589.

hunza@hunza.co.nz www.hunza.co.nz

Specifications may change without notice.

130 Felton Mathew Ave, Glen Innes, Auckland, New Zealand.

3237 Long Island St, W. Sacramento, California 95691, USA.

Manufactured in New Zealand.

Ver 1.2

© 2004 Hunza Holdings Ltd