

Step Lite

Louvre

Cat. No. SLLU

Cat. No. SLLUfl



This luminaire has a flush to the surface look with no protrusions. When using stairs there is no blinding glare or sparkle from the 20 watt lamp to irritate the eyes.

A 240 volt fluorescent option is available which offers excellent light output, low energy usage and very low heat generation, this changes the luminaire to an IP66 rating.

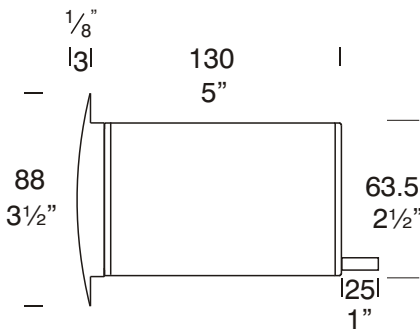
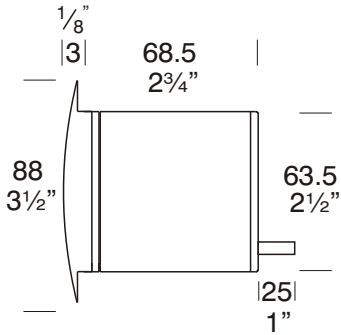

Fluorescent Option

Ordering Information

Luminaire Type	Material	Accessories
SLLU - Step Lite Louvre	COP - Copper SS - 316 Stainless Steel	CJK150 - Cable Joint Kit DFL - Frosted Lens FL - Fluorescent Option Flucan - Fluorescent Canister PVC Sscan - Step Lite Canister Canss - 316 Stainless Steel Canister
<p>Ordering Example SLLU COP - Step Lite Louvre in Copper SLLUFL SS - Step Lite Louvre in 316 Stainless Steel with fluorescent option</p>		
		DFL - Frosted Lens

(Accessories ordered separately)



Patent Pending



FACTORY: Ph: 64-9-528 9471 Fax: 64-9-528 9361.

USA: Ph. 310 560 7310 Fax. 1 877 692 4589.

hunza@hunza.co.nz www.hunza.co.nz

Specifications may change without notice.

130 Felton Mathew Ave, Glen Innes, Auckland, New Zealand.

3237 Long Island St, W. Sacramento, California 95691, USA.

Manufactured in New Zealand.

© 2004 Hunza Holdings Ltd

Ver 1.2

Luminaire Construction

CNC machined from one of the following metals:

Copper: 63.5mm (2½") x 10mm (13/32"). End cap - solid copper 63.5mm (2½") rod.
Flange 90mm (3½") solid copper rod.

316 Stainless steel: 9mm (11/32"). End cap - solid 316 stainless steel 63.5mm (2½") rod.
Flange 90mm (3½") solid 316 stainless steel rod.

Mounting

Designed to fit through a 66mm (2 5/8") hole and be fixed into position by two screws in the flange or a Step Lite canister (see accessories) can be used which maintains the aesthetic look of the flange by eliminating the two screw holes in the flange.

Features

Lens:

3mm (1/8") thick clear tempered shatter resistant glass.

Life Time Warranty.

Gaskets:

Silicone, iron impregnated 220°C (428°F).

Lamp Holders:

GU 5.3 - 350°C (662°F) ceramic multi contact lamp holder with 250°C (480°F) teflon cables.

Fluorescent

E27 PET 210° (410°F) base mount.

Accessories:

Cable Joint Kit (Cat. CJK 50)
Not approved for USA /Canada.

Frosted Lens (Cat. DFL).

Fluorescent Canister, PVC (Cat. Flucan).

Fluorescent Option 5 watt 240 volt (Cat. FL) IP66.

Step Canister (Cat. Slcan).

316 Stainless steel Canister for use in lime stone etc. (Cat. Canss).

Standards

IP66 / IP68



UL1838

Luminaire Weight

12 volt

Cop 1.100kg (2lb 6oz)
SS 1.055kg (2lb 5oz)

Fluorescent IP66

Cop 2.015kg (4lb 7oz)
SS 1.690kg (3lb 11oz)

Power Supply

HUNZA® Inground or Wall Mount
Transformer: not included.

USA and Canada:

HUNZA® Wall Mount Transformer:
not included.

Luminaire: supplied with

Halogen

MR16 GU5.3 20watt lamp max.

Fluorescent

E27 - 240 volt 5 watt self ballasted
lamp.

USA and Canada:

MR16 GU5.3 20 watt lamp max.

Step Lite Louvre Lux MR16 BAB 20 watt lamp - Lens height 400mm (15¾")

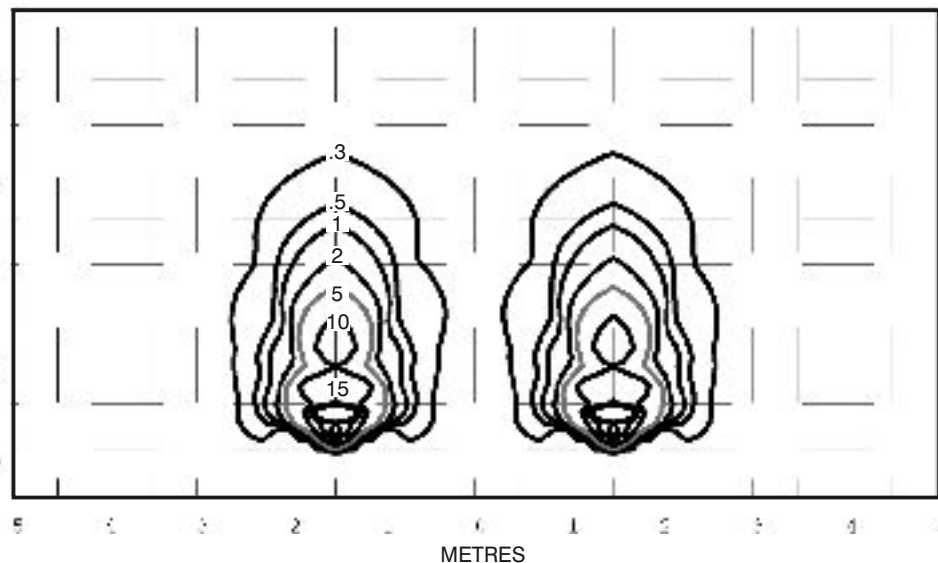
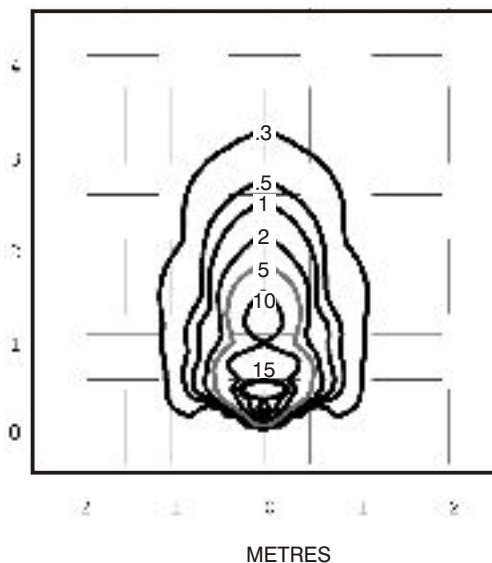

Isolux Lumens Plot - Footcandles = Isolux figures divided by 10.76



FACTORY: Ph: 64-9-528 9471 Fax: 64-9-528 9361.

USA: Ph. 310 560 7310 Fax. 1 877 692 4589.

hunza@hunza.co.nz www.hunza.co.nz

Specifications may change without notice.

130 Felton Mathew Ave, Glen Innes, Auckland, New Zealand.

3237 Long Island St, W. Sacramento, California 95691, USA.

Manufactured in New Zealand.

Ver 1.2

© 2004 Hunza Holdings Ltd