

Step Lite

Cat. No. SL

Cat. No. SLfl



The Step Lite is designed with a 88mm (3½”) flange for flush mounting into masonry, stone or wood. This luminaire is ideal for illumination of steps and ground level horizontal lighting, for example, across driveways or exterior paved areas. When a canister is used there are no mounting holes in the flange.

A 110/240 volt fluorescent option is available which offers excellent light output, low energy usage and very low heat generation, this changes the luminaire to an IP66 rating.

Ordering Information

Luminaire Type

SL - Step Lite

Material/Finish

- BK - Black
- BZ - Bronze
- GN - Green
- STAR - Silver Star
- WH - White
- COP - Copper
- SS - 316 Stainless

Accessories

- CJK150 - Cable Joint Kit
 - LENSSTEPF - Frosted Lens
 - FL - Fluorescent Option
 - HCL - Hex Cell Louvre Adaptor
 - Canss - 316 Stainless Steel Canister
 - Flucan - Fluorescent Canister
 - Slcan - Step Lite Canister
- For an alternative LED option start at page 10.4

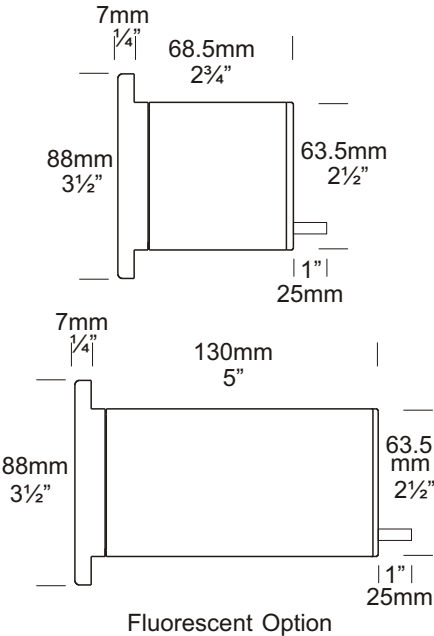

Ordering Example: SL COP - Step Lite in Copper.

HCL COP - Hex Cell Louvre Adaptor in Copper
(Accessories ordered separately)

HUNZA™ PURE OUTDOOR LIGHTING

HUNZA FACTORY
130 Felton Mathew Ave
Glen Innes
Auckland 1072
New Zealand

Ph: 64-9-528 9471
Fax: 64-9-528 9361
hunza@hunza.co.nz
www.hunza.co.nz

INTERNATIONAL CONTACTS:
www.hunza.co.nz/contacts.php
Specifications may change without notice.
Manufactured in New Zealand.
© 2009 Hunza Holdings Ltd.

Ver 1.4

Luminaire Construction

CNC machined from one of the following metals:

High corrosion resistant 63.5mm (2½") x 10mm (25/64") aluminium. End cap - solid aluminium 63.5mm (2½") rod, flange 90mm (3½") solid aluminium rod with chromate substrate and high UV resistant polyester powder coat

Colours Black, Bronze, Green, Silver Star, White.

Copper: 63.5mm (2½") x 10mm (13/32"). End cap - solid copper 63.5mm (2½") rod. Flange 90mm (3½") solid copper rod.

316 Stainless Steel: 9mm (11/32"). End cap - solid 316 stainless steel 63.5mm (2½") rod. Flange 90mm (3½") solid 316 stainless steel rod.

Mounting

Designed to fit through a 66mm (2 5/8") hole and be fixed into position by two screws in the flange or a Step Lite canister (see accessories) can be used, which maintains the aesthetic look of the flange by eliminating the two mounting holes in the flange.

Features

Lens:

10mm (3/8") thick 'flush fit' clear tempered shatter resistant glass. Life Time Warranty.

Gaskets:

Silicone, iron impregnated 220°C (428°F).

Lamp Holders:

GU5.3 - 350°C (662°F) ceramic multi contact lamp holder with 250°C (480°F) teflon cables.

Fluorescent:

E27 PET 210°C (410°F) base mount. E26 is available in the USA.

Accessories:

Cable Joint Kit (Cat. CJK150)

Not approved for USA /Canada.

Fluorescent Option 8watt 240 volt (Cat. FL) IP66.

Frosted Lens (Cat. LENSSTEPF).

Hex Cell Louvre Adaptor (Cat. HCL).

Step Canister (Cat. Slcan).

Fluorescent Canister, PVC (Cat. Flucan).

316 Stainless Canister for use in lime stone etc. (Cat. Canss).

Standards

EN60598

IP66/IP68



UL1838

Luminaire Weight

12 volt

Alum .465kg (1lb)

Cop 1.340kg (2lb 15oz)

SS 1.055kg (2lb 5oz)

Fluorescent IP66

Alum .780kg (1lb 11oz)

Cop 2.275kg (5lb)

SS 1.690kg (3lb 11oz)

Power Supply

HUNZA™ Inground or Wall Mount Transformer: not included.

USA and Canada:

HUNZA™ Wall Mount Transformer: not included.

Luminaire: supplied with

Halogen

MR16 GU5.3 20 watt lamp max.

Fluorescent

E27 - 110/240 volt self ballasted lamp.

LED - Refer sheet no. 10.4

USA and Canada:

MR16 GU5.3 20 watt lamp max.

LED - Refer sheet no. 10.4

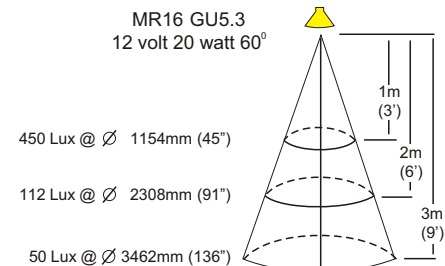
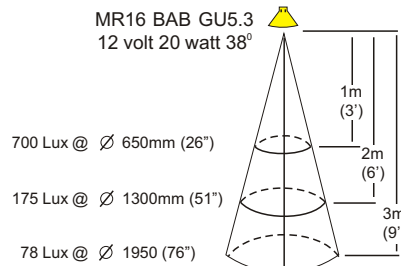
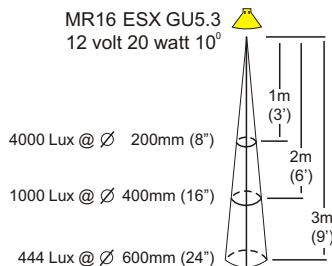

HUNZA™ PURE OUTDOOR LIGHTING

HUNZA FACTORY
130 Felton Mathew Ave
Glen Innes
Auckland 1072
New Zealand

Ph: 64-9-528 9471
Fax: 64-9-528 9361
hunza@hunza.co.nz
www.hunza.co.nz

INTERNATIONAL CONTACTS:
www.hunza.co.nz/contacts.php

Specifications may change without notice.
Manufactured in New Zealand.

© 2009 Hunza Holdings Ltd.

Ver 1.4