

Tree Mount

Cat. No. SSP/T

[Click here for specifications on this luminaire](#)

[Return to main index](#)



The Tree Mount Kit enables a HUNZA® NPS Spot to be mounted onto a tree to create moon lighting effects. A cable connection can be made at the rear of the dome. The Kit consists of a mounting dome and three 316 stainless steel bolts. The bolts initially fix the dome 40mm (1½”) out from the tree’s surface, which allows the tree to grow without causing any harm.

Ordering Information

Luminaire Type

TMK - Tree Mount Kit

Material

Black Polycarbonate

Accessories

CJK150 - Cable Joint Kit

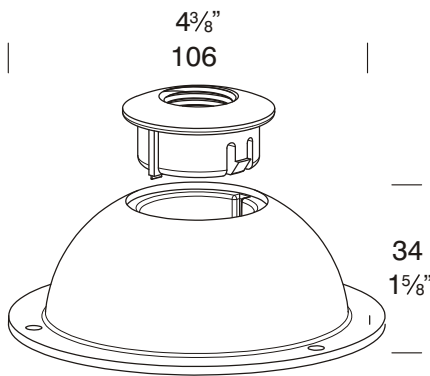

Ordering Example: TMK- Tree Mount Kit in Black

CJK150 - Cable Joint Kit

(Accessories ordered separately)



Patent Pending



FACTORY: Ph: 64-9-528 9471 Fax: 64-9-528 9361.

USA: Ph. 310 560 7310 Fax. 1 877 692 4589.

hunza@hunza.co.nz www.hunza.co.nz

Specifications may change without notice.

130 Felton Mathew Ave, Glen Innes, Auckland, New Zealand.

3237 Long Island St, W. Sacramento, California 95691, USA.

Manufactured in New Zealand.

Ver 1.2

© 2004 Hunza Holdings Ltd

Construction

Dome :

Molded from UV stable polycarbonate with snap in 1/2" NPS female adaptor.

Fixings supplied:

3 x 95mm (3 3/4") 316 stainless steel bolts.

3 x 3mm (1/8") 316 stainless steel screws.

Mounting

The Tree Mount dome is secured to the tree with 3 x 95mm (3 3/4") 316 stainless steel bolts. The HUNZA[®] NPS spot is screwed into the 1/2" nps adaptor.

Features

Dome:

The Dome is fixed 40mm (1 1/2") out from the trees surface by three bolts allowing cabling to be run in behind the dome for connection to the luminaire.

Size:

1/2" NPS

Polycarbonate:

UV stable polycarbonate, suitable for use with aluminium, copper and 316 stainless steel luminaires.

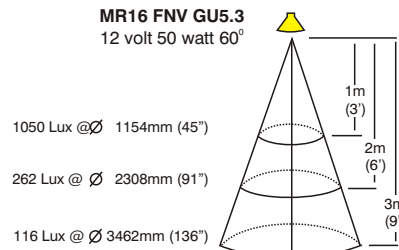
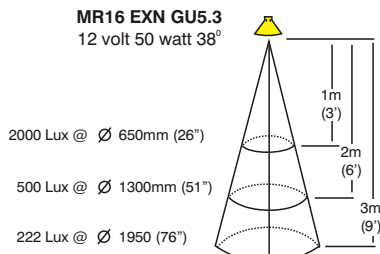
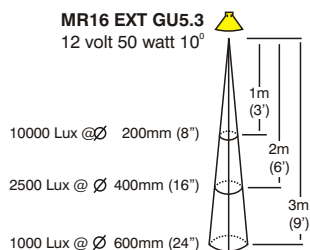
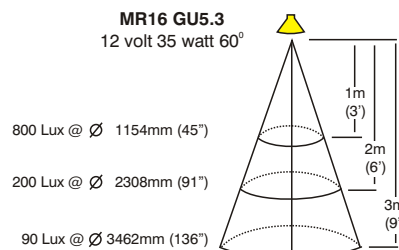
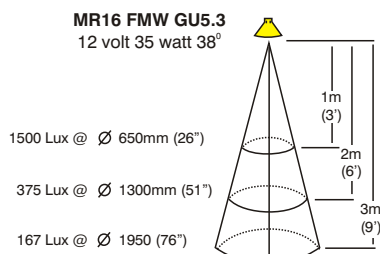
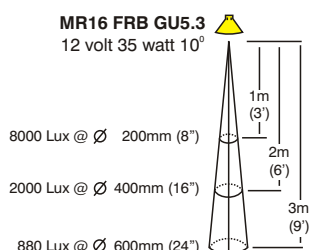
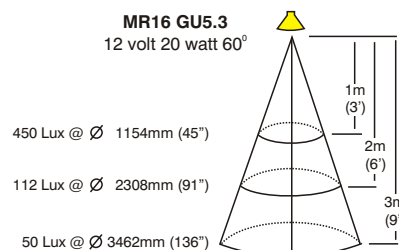
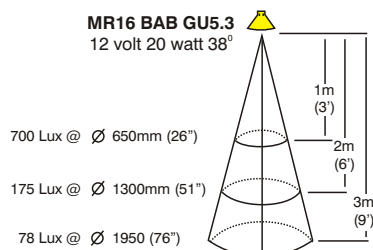
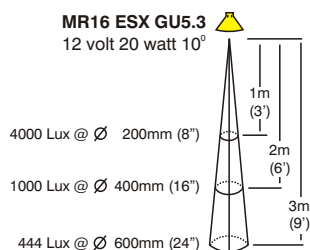

FACTORY: Ph: 64-9-528 9471 Fax: 64-9-528 9361.

USA: Ph. 310 560 7310 Fax. 1 877 692 4589.

hunza@hunza.co.nz www.hunza.co.nz

Specifications may change without notice.

130 Felton Mathew Ave, Glen Innes, Auckland, New Zealand.

3237 Long Island St, W. Sacramento, California 95691, USA.

Manufactured in New Zealand.

© 2004 Hunza Holdings Ltd

Ver 1.2